

SEA DOO

KAWASAKI



SUPER BN MANUAL

For the watercraft tuner working with Super BN series carburetors.

Description	Part No.
Mikuni Manual	53-9999

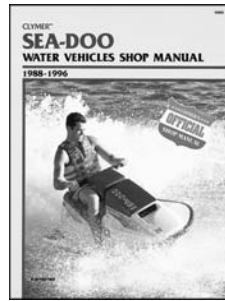

Sea Doo Water Vehicles
1988-1996

Standard GT, GTS, GTX,
SP, SPI, XP

Part No. W809-3

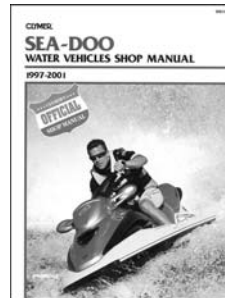

Sea Doo Water Vehicles
1997-2001

GS/GSI/GSX/GSX RFI/
GSX Ltd./GTI/GTS/GTX
GTX DI/GTX RFI/GTX Ltd.
HX/LRV/RX/RX DI
SP/SPX/XP Ltd.

Part No. W810



Kawasaki Jet Ski
1976-1991

JS300, JS550, JS300SX,
JS550SX, JS400, JF650X-2,
JS440, JS650SX, JF650TS,
JL650SC, JB650TS Jet Mate

Part No. W801

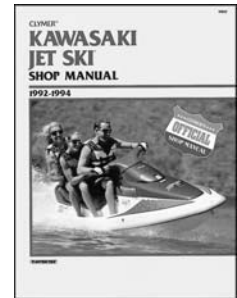

Kawasaki Jet Ski
1992-1994

JS440, JS550, JS550SX,
JB650 Jet Mate, JF650X-2,
JF650TS, JL650SC,
JS650SX, JH750SS,
JS750SX, JH750Xi,
JT750ST, JH750XIR

Part No. W802



Kawasaki Jet Ski
Performance Manual,
all models 1976-1994

Part No. W804

YAMAHA

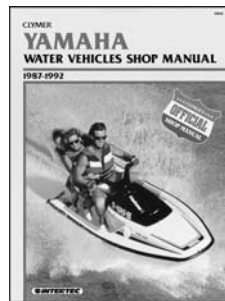

Yamaha Water Vehicles
1987-1992

WJ500, WRA650, WR500,
SJ650, WR650

Part No. W805

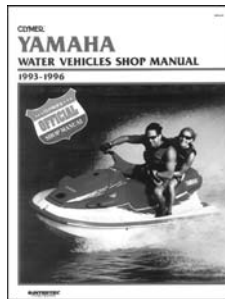

Yamaha Water Vehicles
1993-1996

WR500, SJ650, WR650,
WRA650, WRA650A,
WRB650, WRB650A, FX700,
SJ700, RA700, RA700A,
RA700B, WB700A, WRA700,
WRB700, WVT700, RA760,
WB760, RA1100, WVT100

Part No. W806

POLARIS

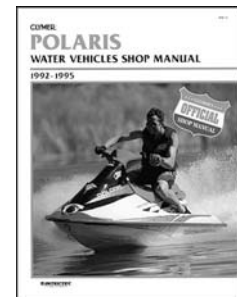

Polaris Water Vehicles
1993-1995

SL650, SL750, SLT750

Part No. W819

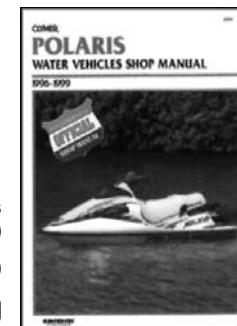

Polaris Water Vehicles
1996-1999

SL650, SL750, SLT750

Part No. W820



2006 WORLD FINALS • LAKE HAVASU, AZ
PHOTO COURTESY OF JIN OMURA

FUEL SYSTEMS
ENGINE/GASKETS
EXHAUST
DRIVE LINE HANDLING
ELECTRICAL
WATERLINE/BILGE
STEERING & CONTROLS
BODY
ACCESSORIES
SERVICE TOOLS
HARDWARE
CHEMICAL
FREESTYLE & BOOSXR
FOUR STROKE

FUEL SYSTEMS
ENGINE/GASKETS
EXHAUST
DRIVE LINE HANDLING
ELECTRICAL
WATERLINE /BILGE
STEERING & CONTROLS
BODY
ACCESSORIES
SERVICE TOOLS /HARDWARE
CHEMICAL
FREESTYLE & 800SXR
FOUR STROKE

METRIC STAINLESS STEEL HEX BOLT PACKS

10 Pcs Per Pack



Size/mm	Part No.
6 x 10	60-3010
6 x 12	60-3012
6 x 14	60-3014
6 x 16	60-3016
6 x 18	60-3018
6 x 20	60-3020
6 x 25	60-3025
6 x 30	60-3030
6 x 35	60-3035

Size/mm	Part No.
6 x 40	60-3040
6 x 45	60-3045
6 x 50	60-3050
6 x 60	60-3060
6 x 70	60-3070
6 x 80	60-3080
8 x 18	60-4018
8 x 20	60-4020

Size/mm	Part No.
8 x 25	60-4025
8 x 30	60-4030
8 x 35	60-4035
8 x 40	60-4040
8 x 50	60-4050
8 x 60	60-4060
8 x 80	60-4080
10 x 25	60-5035

METRIC STAINLESS STEEL ALLEN HEAD BOLT PACKS

10 Pcs Per Pack



Size/mm	Part No.
4 x 30	61-1030
4 x 16	61-1016
5 x 10	61-2010
5 x 25	61-2025
6 x 10	61-3010
6 x 12	61-3012
6 x 14	61-3014

Size/mm	Part No.
6 x 16	61-3016
6 x 20	61-3020
6 x 25	61-3025
6 x 30	61-3030
6 x 35	61-3035
6 x 40	61-3040
6 x 50	61-3050

Size/mm	Part No.
6 x 60	61-3060
8 x 20	61-4020
8 x 25	61-4025
8 x 30	61-4030
8 x 50	61-4050
8 x 60	61-4060
10 x 25	61-5025

METRIC STAINLESS STEEL NUTS

10 Pcs Per Pack

Size	Part No.
6mm	63-0006
8mm	63-0008



METRIC STAINLESS STUD PACKS

10 Pcs Per Pack

Size/mm	Part No.
8 X 30	62-4030



METRIC STAINLESS STEEL FLAT WASHERS

10 Pcs Per Pack

Size	Part No.
6mm	63-2006
8mm	63-2008
10mm	63-2010



METRIC STAINLESS STEEL SPRING WASHERS

10 Pcs Per Pack

Size	Part No.
6mm	63-4006
8mm	63-4008
10mm	63-4010



ZIP TIES



Description	Color	Part No.
3 3/4" x .090	Black	64-0050
7 1/4" x 1.190	Black	64-0051

(Sold in Packages of 100)

PLASTIC FITTINGS



Plastic T Fitting	Part No.
3/8" x 3/8" x 3/8"	64-0025
1/2" x 1/2" x 1/2"	64-0027

Plastic Y Fitting	Part No.
3/8" x 3/8" x 3/8" (white)	64-0045
1/4" x 1/4" x 1/4" (white)	64-0046
1/4" x 1/4" x 1/4" (black)	64-0047

BRASS FITTINGS



Straight Hose Barbed Part No.

1/8" Thread 1/4" Hose	64-0001
1/8" Thread 3/8" Hose	64-0003
1/4" Thread 1/2" Hose	64-0005



Barb Connector Part No.

1/4" I.D. Hose-1/4" I.D. Hose	64-0057
3/8" I.D. Hose-3/8" I.D. Hose	64-0058
1/2" I.D. Hose-1/2" I.D. Hose	64-0059



Brass Push in Nipple Part No.

1/8" Straight	53-9936
1/4" Straight	53-9937



90 Degree Part No.

1/8" Pipe thread 3/8" Hose	64-0007
1/4" Pipe thread 1/2" Hose	64-0009
1/8" Pipe thread 1/4" Hose	64-0010



Garden Hose Adapter Part No.

3/8"	64-0012
1/2"	64-0014



Press-in 90 Degree Fuel Inlet Part No.

1/4" 90 Degree	44
----------------	----



45 Degree Part No.

1/8" Pipe thread 1/4" Hose	64-0065
1/8" Pipe thread 3/8" Hose	64-0066
1/4" Pipe thread 1/2" Hose	64-0067



Brass Fitting Part No.

1/8" Pipe threaded junction	64-0011
1/8" to 1/4" Adapter	64-0013
9mm Yamaha Flush Adapter	64-0004



T-Fitting Part No.

Primer Fitting 1/8" x 1/8" x 1/8"	64-0015
Primer 1/4" x 1/4" x 1/8"	64-0017
Fuel Line 1/4" x 1/4" x 1/4"	64-0019



Brass Threaded Plug Part No.

1/8" Threaded Plug	64-0016
1/4" Threaded Plug	64-0018



2006 WORLD FINALS • LAKE HAVASU, AZ
PHOTO COURTESY OF JIN OMURA

FUEL SYSTEMS	ENGINE/GASKETS	EXHAUST	DRIVE LINE HANDLING	ELECTRICAL	WATERLINE /BILGE	STEERING & CONTROLS	BODY	ACCESSORIES	SERVICE TOOLS /HARDWARE	CHEMICAL	FREESTYLE & BOOSXR	FOUR STROKE
--------------	----------------	---------	---------------------	------------	------------------	---------------------	------	-------------	-------------------------	----------	--------------------	-------------



STAINLESS STEEL HOSE CLAMPS

Clamps	Max. Size	Part No.
#5	(for waterline)	64-0030
#36	2 3/4" - 1 13/16"	64-0032
#48	3 1/2" - 2 9/16"	64-0031
#60	4 1/4" - 3 5/16"	64-0033
#72	5 - 4 1/16"	64-0034
#80	5 1/2" - 4 9/16"	64-0035



T-BOLT CLAMPS

Size	Width	Part No.
3"	3/4"	64-0080
3-1/4"	3/4"	64-0081
4-1/2"	3/4"	64-0082
5"	3/4"	64-0084
5-1/4"	3/4"	64-0085
5-1/2"	3/4"	64-0086



SQUEEZE ON STAINLESS STEEL CLAMPS

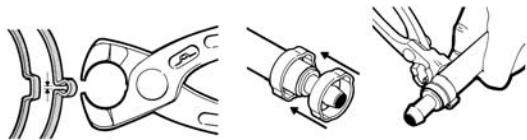

Description	Part No.
Pincer Tool	59-4015
Clamp for 1/4" Hose (10 pcs/pk)	59-4016
Clamp for 3/8" Water Line (10 pcs/pk)	59-4017
Clamp for 1/2" Water Line (10 pcs/pk)	59-4018



HOSE SHEARS

Scissor-action cutter for hose.

Description	Part No.
Hose Shears	59-4020



WATER LINE HOSE

Sold per foot.

Description	Part No.
3/8" Blue	56-8000
1/2" Black	56-8003
1/2" Blue	56-8004
3/8" Clear Vinyl	56-8007
3/8" Light Blue, Soft	56-8010



FUEL FEED AND VENT HOSE

Designed to meet fuel hose specification for SAE J1527 and ISO 7840. This hose meets all the requirements of the USCG, NMMA, ABYC. 25 feet/pk.

Description	Part No.
1/4" Fuel Feed & Vent Hose	360-014



FUEL LINE

Fuel line is made from a thick walled polyurethane tubing. Sold per foot. or 25 feet/pk

Description	Part No.
Blue (1/4") per foot	53-9970
Blue (1/4") 25 feet/pk	53-9970-25
Primer Line (1/8") per foot	53-9980
Primer Line (1/8") 25 feet/pk	53-9980-25

FUEL SYSTEM SERVICE TOOLS

FUEL SYSTEMS
ENGINE/GASKETS
EXHAUST
DRIVE LINE HANDLING
ELECTRICAL
WATERLINE /BILGE
STEERING & CONTROLS
BODY
ACCESSORIES SERVICE TOOLS /HARDWARE
CHEMICAL
FREESTYLE & BOOSXR
FOUR STROKE



CARB SCREW ADJUSTING TOOL

Angled head for the hard-to-reach carb adjustment screws

Description	Part No.
Carb Screw Adjusting Tool	53-9994



90 DEGREE 1/4" HEX DRIVER

Precision made of high-grade aluminum & stainless steel. Designed for hard-to-reach pilot screw. Gear driven 1/4" hex. Includes 1/4" hex bits, straight slot, Phillips, D-shaped pilot screw bit, 6mm hex jet bit and 1/4"-hex-to-1/4" drive bit.

Description	Part No.
90 Degree 1/4" Hex Driver	08-0229

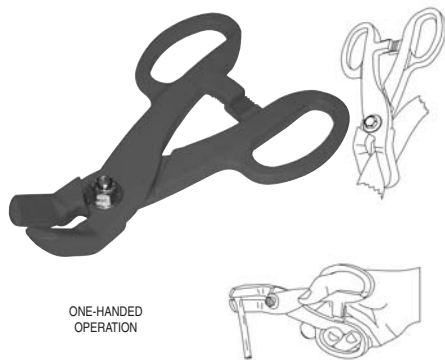

ONE-HANDED OPERATION

HOSE PINCHER

Clamps and holds hoses up to 3/4" inside diameter. Angled jaws close to create a complete seal every time. Jaws are offset for hard-to-reach areas. The handles lock firmly to hold the jaws in closed position.

Description	Part No.
Hose Pinchers	LS23000

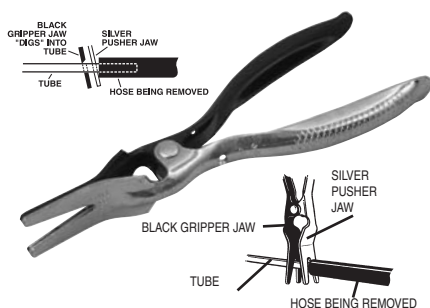

HOSE REMOVAL PLIERS

For easy removal of 5/32" to 1/2" (4mm to 14mm) hoses. Engage the tube (line) with the black jaw. This sharpened jaw actually "digs" into the tube to grip it! Squeeze, and the hose is easily pushed off by the silver jaw.

Description	Part No.
Hose Removal Pliers	LS47900

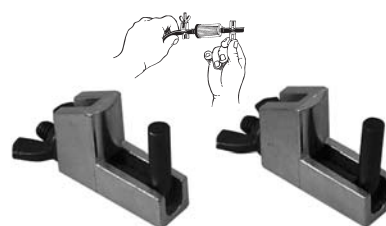

HOSE PINCHERS

Quick, easy way to pinch off fuel lines, etc. without damaging the line. Sold two per set.

Description	Part No.
Hose Pinchers	LS22850



MIKUNI TOOL KIT

This handy little kit contains all the tools necessary to make jetting change, perform normal maintenance as well as disassemble and rebuild any Mikuni carburetor

Description	Part No.
Mikuni Tool Kit	53-9989



HAND REAMER JET SET

Cleans jets the right way.

Description	Part No.
6pcs Reamer Jet Set	59-0603

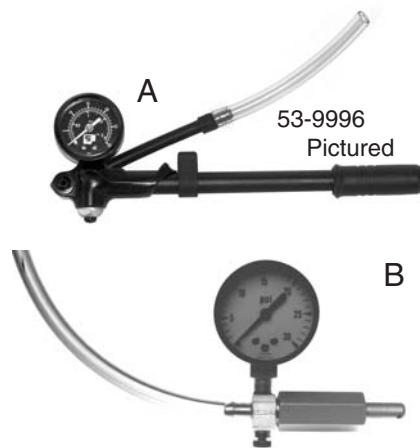

POP-OFF GAUGE

For Accurate adjustment of pop off pressure levels.

Description	Part No.
A Mikuni Gauge	
30 Lbs.	53-9996
60 Lbs.	53-9996-60
100 Lbs.	53-9996-100
B Aftermarket Thumb Operated Gauge	53-9995



ROTARY VALVE TIMING WHEEL

Description	Part No.
Rotary Valve Timing Wheel	012-170

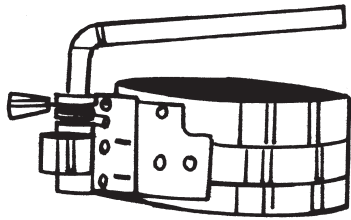

QUICK RELEASE RING COMPRESSOR

Ring Compressor makes it easy to remove ring from piston. Range is from 2-1/8" – 5" (54mm–127mm).

Description	Part No.
Quick Release Ring Compressor	LS19000

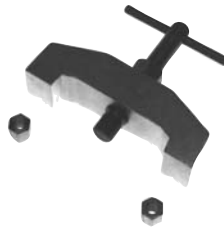

HEAD PULLER FOR KAWASAKI HEADS

Pull straight up from the spark plug hole while using the studs for leverage.

Description	Part No.
Head Puller for Kawasaki	59-0209

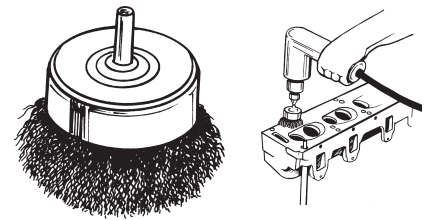

2-1/2" WIRE CUP BRUSH

Removes weld scale, rust, paint and corrosion from metal surfaces. Made with .014 carbon steel wire and designed for light duty use with an electric drill. Maximum safe free speed is 4500rpm.

Description	Part No.
2-1/2" Wire Cup Brush	LS14020

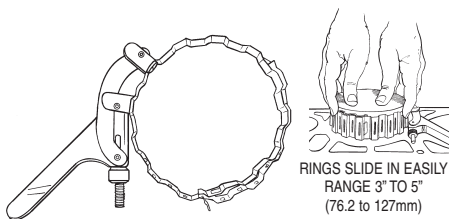

RINGS SLIDE IN EASILY
RANGE 3" TO 5"
(76.2 to 127mm)

WRINKLE BAND RING COMPRESSOR

Wrinkle band cuts friction in half. Rings slide in easily 3" – 5" (76.2mm – 127mm).

Description	Part No.
Wrinkle Band Ring Compressor	LS21700



SEAL PULLER

Simply insert the tip of the tool behind the oil or grease seal, press and pull. Leverage works for you. Two size tips reach in and fit nearly all seal applications.

Description	Part No.
Seal Puller	LS56750

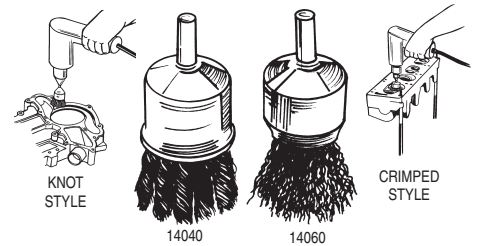

1" WIRE END BRUSHES

Made with .020" industrial heat-tempered wire. Use with portable electric and air tools. 20,000rpm maximum safe speed.

Description	Part No.
1" Knot Wire End Brush	LS14040
1" Crimped Wire End Brush	LS14060

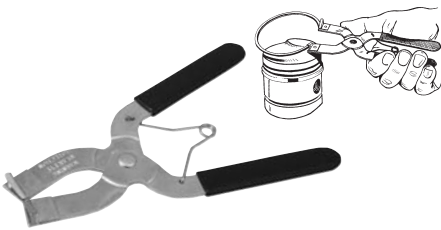

PISTON RING INSTALLER

Description	Part No.
Piston Ring Installer	LS33500

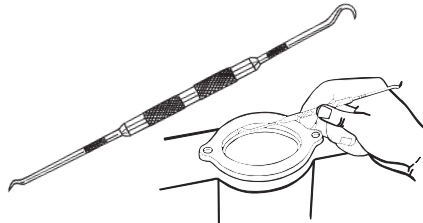

"O" RING AND SEAL PICK

Quickly removes and installs "O" rings and seals. Tips are hardened to stay sharp.

Description	Part No.
"O" Ring and Seal Pick	LS31840



PISTON PIN PULLER

Universal piston pin puller easily removes all sizes of piston pins without any damage to the piston.

Description	Part No.
Piston Pin Puller	59-0252

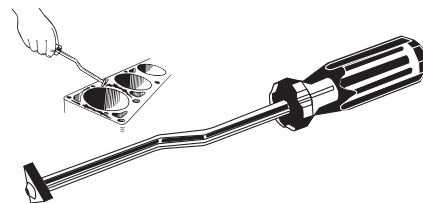

CARBIDE GASKET SCRAPER

Six-sided carbide blade cuts smoother and lasts longer.

Description	Part No.
Carbide Gasket Scraper	LS51650
Replacement Carbide Blade	LS51660

CONVERSION TABLE

Unit	Conversion
Linear Measure	
centimeter (cm.)	0.3937 inch
meter (m.)	3.2808 feet / 1.0936 yards
kilometer (km.)	0.6214 mile
inch (in.)	2.54 centimeters
foot (ft.) = 12 inches	30.48 centimeters
yard (yd.) = 3 feet	0.914 centimeters
rod (rd.) = 5.5 yards	5.0292 meters
chain (ch.) = 4 rods	20.117 meters
furlong (fur.) = 10 chains	201.17 meters
mile (m., mi.) = 8 furlongs	1.6093 kilometers
league (l.) = 3 miles	4.8279 kilometers
Aviordupois Weight	
Gram (g.)	0.0353 oz. avdp.
kilogram (kg.) = 1,00 grams	2.2046 lb. avdp
metric ton (M.T.)	1.1023 short tons
	0.9842 long ton
grain (gr.)	0.0648 gram
dram (dr. avdp.) = 27.34 grains	1.7718 grams
ounce (oz. avdp.) = 16 drams	28.3495 grams
pound (lb. avdp) = 16 ounces	0.4536 kilogram
hundredweight (cwt.)	
(US) = 100 pounds	45.3592 kilograms
(UK) = 112 pounds	50.8024 kilograms
ton (t., tn.)	
(US) = short ton	
=2,000 pounds	0.907 metric ton
(UK) = short ton	
=2,240 pounds	1.106 metric ton

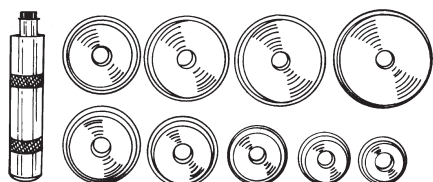

SET INCLUDES ONE OF EACH OF THE FOLLOWING DRIVERS:

DRIVER PART NO.	SIZE
12610	1.565"
12620	1.750"
12630	1.965"
12640	2.325"
12710	2.470"
12650	2.555"
12690	2.830"
12700	2.995"
12970	3.180"

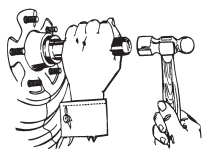

BEARING RACE AND SEAL DRIVER—MASTER SET

Make it easier to insert bearing race and seals without damage to race. This master set includes nine drivers to fit most standard bearings.

Description	Part No.
Bearing Race and Seal Drive	LS12980
Handle Mini pouched	LS12660



COMPRESSION TESTER

Contains hoses for 10, 12 & 14mm spark plug applications. Features a quick disconnect with a pressure release valve and a 300lbs. Gauge. Packed in a convenient carry box. Made in USA.

Description	Part No.
Compression Tester	08-0188

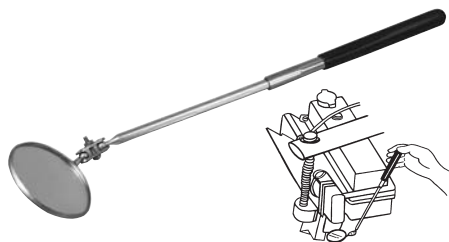

TELESCOPING MIRROR

Enables you to see around corner. 2-1/4" diameter mirror swivels to any position. Length extends from 10" to 14".

Description	Part No.
Telescoping Mirror	LS32050



JUMPER CABLES

8 feet long heavy duty 8 gauge copper jumper cables are big on charging power, yet stow conveniently in the 9 x 9 inch nylon bag.

Description	Part No.
Jumper Cables	59-0530



SPARK PLUG TOOLS

Description	Part No.
Ratchet Plug Wrench	59-0539



SPARK PLUG WIRE TESTER

Now you can check spark plug wires without piercing the wires. Light flashes indicating sound wire.

Description	Part No.
Spark Plug Wire Tester	LS26900
Replacement Bulb Assembly	LS26970



IGNITION SYSTEM SPARK TESTER

This ignition system tester checks the integrity and strength of your system by gauging your systems spark.

Description	Part No.
Ignition System Spark Tester	59-0253

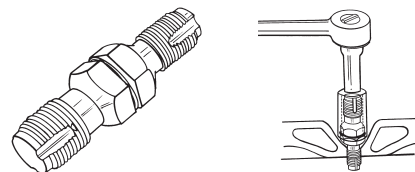

SPARK PLUG HOLE THREAD CHASER

Cleans threads in spark plug hole. Use with 13/16" spark plug socket. Double-ended for both 14mm and 18mm threads.

Description	Part No.
Spark Plug Hole Thread Chaser	LS20200

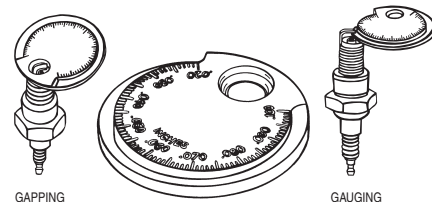

STANDARD/HIGH ENERGY SPARK PLUG GAUGE AND GAPPER

Gauge and gap all types of spark plugs from .020" to .110 (.50mm to 2.53mm).

Description	Part No.
Spark Plug Gauge and Gapper	LS67870

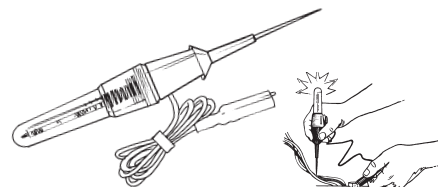

LOW CIRCUIT TESTER

Quick check both AC and DC current up to 28 volts with power on. Helps locate shorts or breaks in wiring. Complete with insulated grounding grip.

Description	Part No.
Low Circuit Tester	LS26250
Replacement Bulb	LS26270



SPARK PLUG HOLDERS

Spark Plug Holder protects the electrode, maintaining the proper gap.

Description	Part No.
2 per blister pack	SPH-2
40 per countertop display	SPH-40

FUEL SYSTEMS
ENGINE/GASKETS
EXHAUST
DRIVE LINE HANDLING
ELECTRICAL
WATERLINE /BILGE
STEERING & CONTROLS
BODY
ACCESSORIES
SERVICE TOOLS /HARDWARE
CHEMICAL
FREESTYLE & BOOSXR
FOUR STROKE



WATERPROOF TERMINAL REPAIR KIT

Description	Part No.
Japanese OEM Type Connector Kit	59-0601



PERMA-SEAL CONNECTOR KIT

Description	Part No.
MSD Perma-Seal Connector Kit	4377



FLYWHEEL PULLER

Description	Part No.
Sea Doo 800/951 38mm x 1.5	MP#42
Kawasaki 900/1100 35mm x 1.5	DS#29



PRO-CRIMP TOOL

To do a job right, it is important to have the right tools. If you custom build a lot of plug wires, the Pro-Crimp is the right tool for you! The Pro-Crimp features a hardened steel frame, molded hand grips and built-in ratchet action that is also adjustable. The tool is supplied with jaws to fit MSD's Super Conductor Spark Plug wires and can be removed to use additional jaws (sold separately) for crimping common wiring terminals.

Description	Part No.
MSD Pro Crimp Tool	3505
Spark Plug Dies	3508
Amp Pins	3506
Amp Lug Dies	3507
Weathertight Dies	3509
Deutsch Terminal Dies	3510



TIMING LIGHTS

MSD offers a heavy duty top quality timing light. This timing light is supplied in a heavy duty metal housing and features a high output Linear Xenon strobe with a focused fresnel lens that produces a light that's bright enough to use outdoors. It is equipped with a 6 foot lead and uses a metal inductive pickup that clamps to the spark plug wire.

Description	Part No.
Timing Light	8990

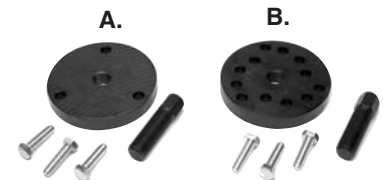

MAGNETO FLYWHEEL PULLER

Sea Doo	Part No.
A. 580/650/720 3 Hole Disc 8mm Bolts	DS#34
Polaris	
B. Polaris ALL & Universal Universal 12 Hole Disc 8mm Bolts	DS#37



MAGNETO FLYWHEEL PULLER

YAMAHA	Part No.
C. 500/650/Pre 94 701 3 Hole Disc 8mm Bolts	DS#26
D. 701/760/800/1100/1200 3 Hole Disc 8mm Bolts	DS#37



TERMINAL DETENT TOOL

The hollow barrel allows you to depress the tab on the terminal end and to remove the wire from the connector without damaging its ends.

Description	Part No.
Terminal Detent Tool	59-0254



TDC DIAL INDICATOR KIT

Perfect for indicating TDC (Top Dead Center) when setting ignition and rotary valve timing. CNC-machined spark plug hole (14mm) adapter. 1" travel dial indicator. Rotating Bezel. Measures in .001" increments.

Description	Part No.
TDC Indicator	MT-DIAL



TIMING DEGREE WHEEL

Set total loss timing with no guess work. Check crank shaft timing to exact degree. A must for porting and port timing.

Description	Part No.
Timing Degree Wheel	08-0092



MAGNETO FLYWHEEL PULLER

KAWASAKI	Part No.
E. 300/440/550/650 3 Hole Disc 8mm Bolts	DS#37
F. 750/800 Special 18mm x 1.5 Right Hand Bolt	MP#18

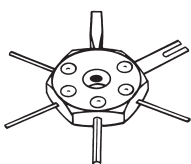

TERMINAL REMOVAL TOOL

Includes six different shaped blades.

Description	Part No.
Terminal Removal Tool	LS14900

PUMP SYSTEM SERVICE TOOLS AND SHOP TOOLS



IMPELLER HOLDER TOOL

Sea Doo	Part No.
A. 580/650/720/800/951 All 18mm spline	DS#23
POLARIS	Part No.
B. Polaris ALL & long reach univ.	DS#38



IMPELLER HOLDER TOOL

Sea Doo	Part No.
K. GTX 4Tec Super Charged	DS#70
L. RXP	DS#71



SHOP LANYARD

Not legal for riding. For shop testing only.

Description	Part No.
KPTW, Yamaha, Sea Doo	A3240
KPTW, Yamaha, Sea Doo DESS	A3250

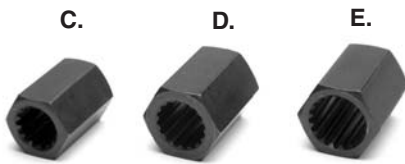

IMPELLER SHAFT HOLDER TOOL FOR YAMAHA

Yamaha	Part No.
C. WR500, WJ650LX 16mm spline	DS#27
D. 650/701/760/1100/1200 18mm spline	DS#32
E. GP1200R 20mm spline	DS#56

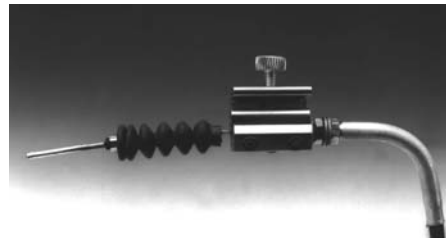

CABLE LUBBER

Installs quickly and helps free up corroded or tight cables. Note; Damaged cable should be replaced.

Description	Part No.
Cable Lubber	59-0250



RATIO CUP & LID

Description	Part No.
Ratio Cup	59-0548
Lid	59-0582

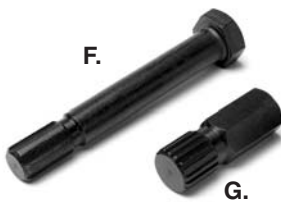

IMPELLER HOLDER TOOL

Kawasaki	Part No.
F. 440/550-89 16mm spline	DS#24
G. 650/750/900/1100 18mm spline	DS#23

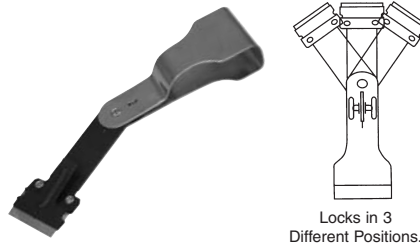

Locks in 3 Different Positions.

FOLD-UP SCRAPER

The fold-up scraper features three arm positions and a slanted blade for proper scraping. Great for removing decals, etc.

Description	Part No.
Fold-up Scraper	LS52400



HYDRO-TURF OIL EXTRACTOR

The unit uses a small vacuum system, which pumps fluid through a hose to the 6-liter reservoir. It also includes a pour spout to aid in emptying the reservoir. Pump is removable for easy storage.

Description	Part No.
Hydro-Turf Oil Extractor	OIL01



DRIVE COUPLER TOOLS

Use to remove drive coupler from crankshaft and sub-shaft.

Description	Part No.
650/701	DS#60-3
760/800/110/1200	DS#61-5

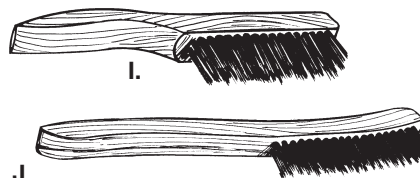

SCRATCH BRUSH

Removes rust, scale, paint, and solder from metal surfaces.

Description	Part No.
I. Shoe Handle Scratch Brush	LS14180
J. Scratch Brush	LS14160

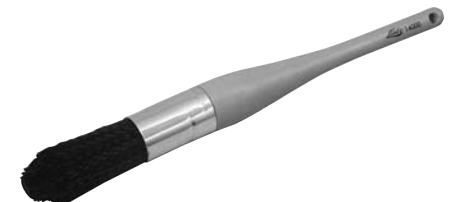

PARTS CLEANING BRUSH

Description	Part No.
Parts Cleaning Brush	LS14000

FUEL SYSTEMS	ENGINE/GASKETS	EXHAUST	DRIVE LINE HANDLING	ELECTRICAL	WATERLINE /BILGE	STEERING & CONTROLS	BODY	ACCESSORIES	SERVICE TOOLS /HARDWARE	CHEMICAL	FREESTYLE & BOOSXR	FOUR STROKE
--------------	----------------	---------	---------------------	------------	------------------	---------------------	------	-------------	-------------------------	----------	--------------------	-------------

FUEL SYSTEMS
ENGINE/GASKETS
EXHAUST
DRIVE LINE HANDLING
ELECTRICAL
WATERLINE /BILGE
STEERING & CONTROLS
BODY
ACCESSORIES
SERVICE TOOLS /HARDWARE
CHEMICAL
FREESTYLE & 800SKR
FOUR STROKE

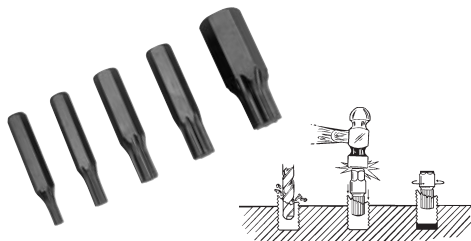

SUPER OUT SET

A super strong extractor set made of a special hardened, shock-resistant tool steel. Works on both left and right hand threads. Super Outs cut their way straight into bolts, eliminating wedging or further tightening of frozen bolts and screws. Five extractor sizes extract 1/4" to 1/2" and larger bolts and screws.

Description	Part No.
Super Out Extractor Set	62900



STUD INSTALLATION TOOLS

Will Install cylinder and intake manifold studs. Hex head is 3/4" or 19mm.

Description	Part No.
6mm x 1.00 Stud Tool	59-0212
8mm x 1.25 Stud Tool	59-0213
10mm x 1.25 Stud Tool	59-0214



IMPACT DRIVER SET

For easy removal of Mikuni Valve body screws without damage.

Description	Part No.
Impact Driver Set	59-0605



TORX® SOCKET SET FOR SEA DOO

Special Star Sockets for Sea Doo 4-Tec & DI engine bolts are made from heat-treated vanadium steel and black oxide coated for durability. Sockets are kept in a convenient vinyl holder.

- Four 3/8" Drive Sockets (T10, T12, T14, T16)
- Three 1/4" Drive Sockets (T6, T7, T8)

Description	Part No.
Torx Socket Set	LS26750



T-HANDLE RATCHET

Features a compact design that allows it to be used even in tight spaces.

Description	Part No.
1/4" T-Handle Ratchet	08-0231
3/8" T-Handle Ratchet	08-0226



BALL END ALLEN SET

Made of chrome-vanadium tool steel. Size available 1.5, 2, 2.5, 3, 4, 5, 6, 8, & 10mm. Ball end allows for better access to allen-head bolts (up to 25 degree working angle.)

Description	Part No.
Ball End Allen Set	08-0185



T-HANDLE ALLEN WRENCH

Description	Part No.
5mm – 6" long T-Handle	59-0307
5mm – 9" long T-Handle	59-0309
8mm – 9" long T-Handle	59-0311



DOC ALLEN'S VERSATOOL

- Lightweight
- Compact
- Multi-Function
- Stainless Steel
- Use in Tight Places

Description	Part No.
Compact Tool Set	VERSATOOL



MAGNETIC SOCKET HOLDERS

Standard and deep sockets fit on one convenient holder with powerful magnets, securely holding on to any steel surface. Red color only.

Description	Part No.
1/4" Holder with 26 compartments	LS40120
3/8" Holder with 28 compartments	LS40200

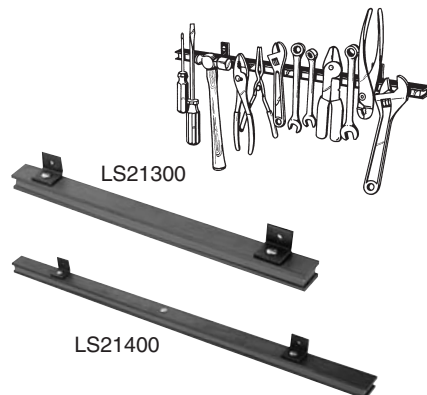

MAGNETIC TOOL HOLDERS

Powerful magnet holds even heavy hand tools. Ideal for both home and shop.

Description	Part No.
13" long Magnetic Tool Holder	LS21300
24" long Magnetic Tool Holder	LS21400

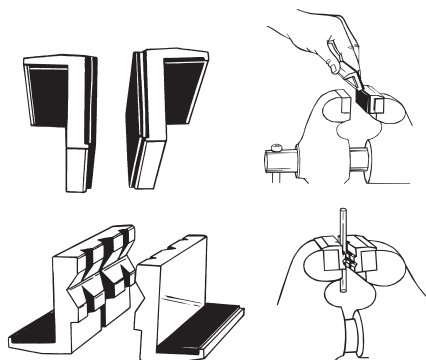

RUBBER-FACED & ALUMINUM VISE JAW PADS

These vise jaw pads are designed to protect delicate parts from damage. Sold in pairs.

Description	Part No.
A. Rubber-faced Vise Jaw Pads	LS48100
B. Aluminum Vise Jaw Pads	LS48000