



MIKUNI CARBURETORS

HI-PERFORMANCE SUPER BN

Extended Throttle Shaft Without Choke Shaft



38MM

Part # **53-2050**
Mikuni # BN38-34-8113



44MM

Part # **53-2060S**
Mikuni # BN44-40-8067



44MM

Part # **53-2060**
Mikuni # BN44-40-8052



46MM

Part # **53-2065**
Mikuni # BN46-42-8002



38MM FOR DUAL FRONT CARB

Part # **53-2074**
Mikuni # BN38-34-8075

**Rear side carb no longer available*

OEM REPLACEMENT SUPER BN

Regular Throttle Shaft With Choke Shaft

**** Direct replacement of OEM Carburetors at a fraction of OEM cost. ****



MAG-SIDE

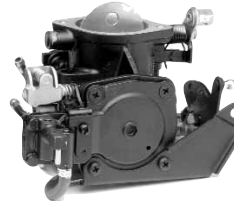

PTO-SIDE



44MM - I-SERIES

Part # **53-2080**
Mikuni # BN40I-38-24
Sea Doo 720,
GTI, GTS, GS,
GSI, '97

40MM - I-SERIES

MAG-SIDE (FRONT)
Part # **53-2085** Mikuni # BN40I-38-26
PTO-SIDE (REAR)
Part # **53-2090** Mikuni # BN40I-38-27
Sea Doo 720 GTI, GTS, GS, GSI '98, 800 GTX,
GSX '96-'00, 800 SPX 97-99, 800 XP '95-'99,
951 GSX LTD '97



38MM

Part # **53-2063**
Mikuni # BN34-28-8010
Yamaha,
Wave Runner 500 88-89
Wave Jammer 500 88-89



44MM

Part # **53-2062**
Mikuni # BN44-40-43
Yamaha Superjet,
Wave Blaster,
Tigershark



44MM - I-SERIES

Part # **53-2072**
Mikuni # BN40I-38-II
Sea Doo 720
XP '95 PTO



DUAL CARBURETOR SET

46MM - I-SERIES

Part # **53-2095**
Mikuni # BN46I-42-B4
Sea Doo 951
GSX, GTX, XP-LTD, '98-01
XP'00, RX, LRV

**Sold as a fully assembled dual carb set.*

FUEL SYSTEMS

ENGINE/GASKETS

EXHAUST

DRIVE LINE HANDLING

ELECTRICAL

WATERLINE /BILGE

STEERING & CONTROLS

BODY

ACCESSORIES

SERVICE TOOLS /HARDWARE

CHEMICAL

FREESTYLE & 800SXR

FOUR STROKE



GENUINE CARBURETOR REBUILD KITS

Kits include all necessary gaskets, diaphragms, and hardware required to disassemble and rebuild Mikuni carburetor.



Mikuni	Diaphragm Cover	Part No.
Super BN 38mm, 44mm, 46mm I Series 38/40	Square	53-2114
*Sea Doo Pre 97, Kawasaki 750 98-02, 800 SX-R 03-05 and ALL Mikuni Performance Super BN Square Body 38mm, 44mm and 46mm carbs.		
I Series 46mm	Square	53-2115
*Sea Doo 951 98 and newer		
I Series 44mm	Square	53-2117
*Yamaha GP800 98-99, GP 800R 00-04, XL 800 01, XLT 800 02-04, GP 1200R 00-02, XL1200 Limited 99-00 and XLT 1200 01-04		
BN 38mm, 44mm	Round	53-2110
*BN carbs are "Old Style/Round Body" with round diaphragm covers		

POP-OFF GAUGE

For Accurate adjustment of pop off pressure levels.

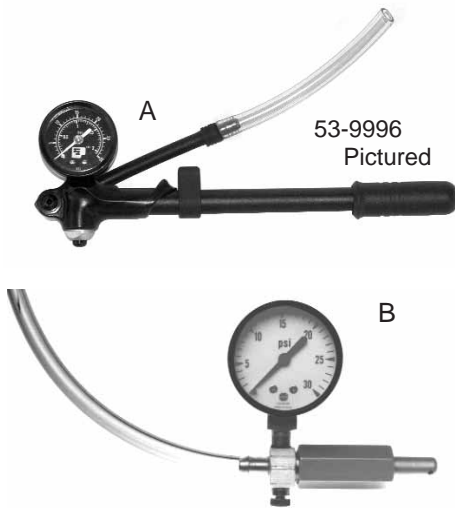

Description	Part No.
A Mikuni Gauge	
30 Lbs.	53-9996
60 Lbs.	53-9996-60
100 Lbs.	53-9996-100
B Aftermarket Thumb Operated Gauge	53-9995



MIKUNI TOOL KIT

This handy little kit contains all the tools necessary to make jetting change, perform normal maintenance as well as disassemble and rebuild any Mikuni carburetor.

MIKUNI POCKET TUNER

A handy pocket-size slide calculator which can be used to determine required jetting changes in Mikuni carburetors due to ambient temperature, altitude or both.



Description	Part No.
Mikuni Pocket Tuner	53-9988

Description	Part No.
Mikuni Tool Kit	53-9989

MIKUNI SUPER BN SPECIFICATIONS

Hot Part #	Carb.	Low Speed Jet	High Speed Jet	Needle Valve	Arm Spring (grams)	Low Speed Adjuster	High Speed Adjuster	Choke or Primer	Color
53-2050	BN38-34-8113	65	107.5	2.0	115 gr.	1.0	1.5	Primer	Silver
53-2060	BN44-40-8052	100	125	2.3	65 gr.	1.0	1.5	Primer	Black
53-2060S	BN44-40-8067	120	140	2.5	80 gr.	1.0	1.5	Primer	Silver
53-2065	BN46-42-8002	120	150	2.5	80 gr.	1.0	1.5	Primer	Silver
53-2062	BN44-40-43	120	115	1.5	115 gr.	1.0	.75	Choke	Black
53-2063	BN34-28-8010	77.5	80	1.5	65 gr.			Choke	Black
53-2072	BN40I-38-II		147.5	1.5	80 gr.			Choke	Black
53-2074	BN38-34-8075	65	107.5	2.0	115 gr.			Primer	Black
53-2080	BN40I-38-24	70	167.5	1.5	95 gr.	1.25	closed	Choke	Black
53-2085	BN40I-38-26	67.5	140	1.5	95 gr.	1.25	closed	Choke	Black
53-2090	BN40I-38-27	67.5	142.5	1.5	95 gr.	1.25	closed	Choke	Black
53-2095	BN46I-42-B4	77.5	162.5	2.0	95 gr.	1.25	closed	Choke	Black

FUEL SYSTEMS
 ENGINE/GASKETS
 EXHAUST
 DRIVE LINE HANDLING
 ELECTRICAL
 WATERLINE /BILGE
 STEERING & CONTROLS
 BODY
 ACCESSORIES
 SERVICE TOOLS /HARDWARE
 CHEMICAL
 FREESTYLE & 800SXR
 FOUR STROKE



SUPER BN 44/46

Socket Bolt Kit

59-9131

See bottom of page

- * Super BN38 and Late Super BN44
- ** Early Super BN44

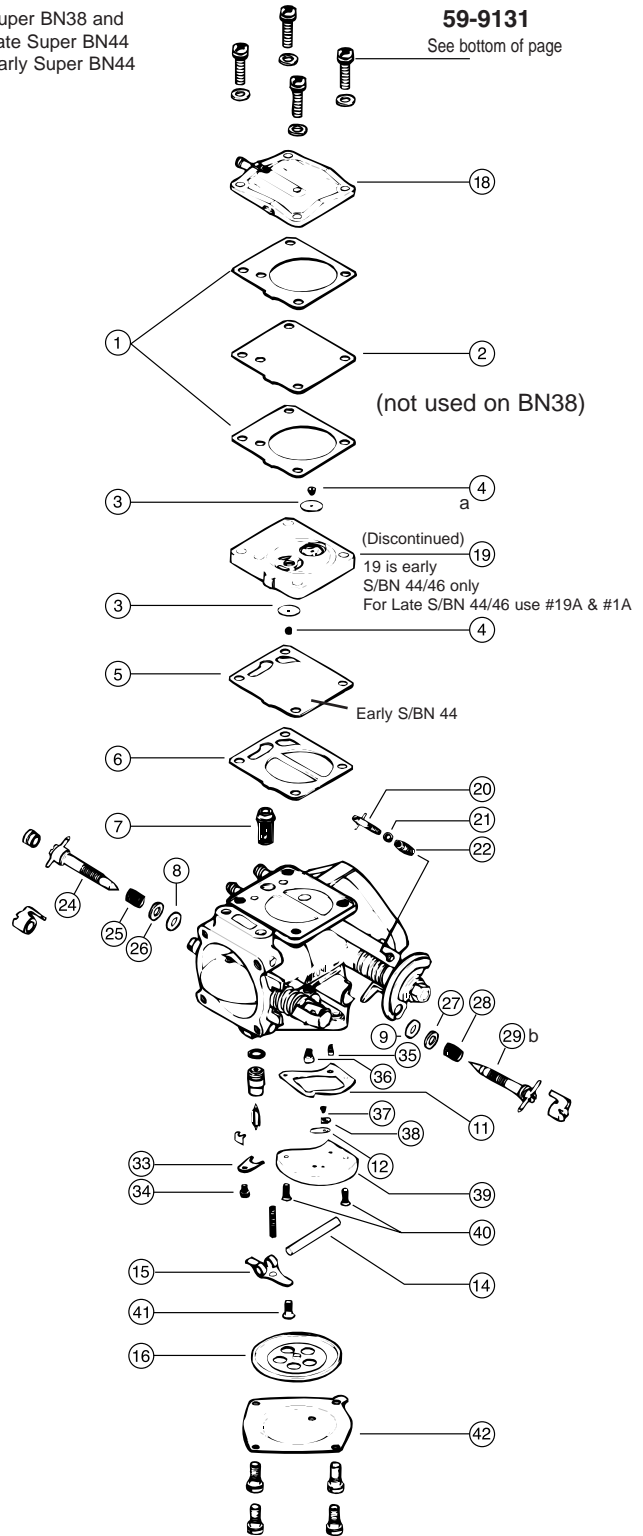

MIKUNI GENUINE PARTS SUPER BN38 / BN44 / BN46

Diagram No.	Description	Mikuni Part No.
1.	Gasket Pump (2)	.BN38/547
1a.	O-Ring*	.616-72001
2.	Diaphragm, Pump (Clear)	.BN34/97
3.	Check Valve (2) (Clear)	.BN34/124
4.	Grommet, Check Valve (2)	.BN34/125
5.	Diaphragm, Damper (large hole)**	.BN34/100
5a.	Diaphragm, Damper (small hole)*	.BN34/129
6.	Gasket, Damper**	.BN34/101
6a.	O-Ring*	.616-92007
7.	Filter	.BN44/146
8.	O-Ring, Hi Speed	.B30/305
9.	O-Ring, Low Speed	.MD12/16
11.	Gasket Valve Body	.BN34/123
12.	Check Valve (Clear)	.BN34/107
14.	Pin, Arm	.VM30/97
15.	Arm (Stainless)	.BN38/534
16.	Diaphragm Assembly	.BN44/145
18.	Cover Pump	.BN34/95B
19a.	Body Assembly Pump* (Must use w/O-Ring 1A)	.BN34/128
20.	Stop Screw, Idle**	.BN44/109
20a.	Stop Screw, Idle*	.BN34/82
21.	Washer (Aluminum - Same as #26)	.BN38/39
22.	Spring, Idle**	.BN38/341
22a.	Spring, Idle (Same as #25)*	.BN38/344
24.	Adjuster, Hi Speed (with Cross Bar)	.BN44/167
25.	Spring, Hi Speed (Same as #22a)	.BN38/344
26.	Washer, Hi Speed (Aluminum - Same as #21)	.BN38/39
27.	Washer, Low Speed (Aluminum)	.BN38/172
28.	Spring, Low Speed	.BN38/343
29a.	Adjuster, Low Speed (with Cross Bar) 38mm	.BN38/477
29b.	Adjuster, Low Speed (with Cross Bar) 44mm	.BN38/166
33.	Plate, N.V. Retainer	.BN34/117-GG
34.	Screw with washer	.CW2-0307-G
35.	Low Jet, 30-160 in increments of 5	.N100.606-SIZE
36.	Main Jet, 30-260 in increments of 5	.N102.221-SIZE
37.	Screw	.BV15/121-05-GG
38.	Plate, Valve	.BN34/108-GG
39.	Valve Body Assembly	.BN44/165
40.	Screw (2 pcs)	.C5-0414-G
41.	Screw	.C6-0308-G
42.	Cover (Stainless)	.BN44/147

* Super BN38 and Late Super BN44
** Early Super BN44



SUPER BN CARBURETOR TUNING MANUAL

For the watercraft tuner working with
Super BN series carburetors.

Description	Part No.
Mikuni Manual	53-9999



CARBURETOR SOCKET BOLT KIT

Replace the stock phillips bolts on
carbs with stainless steel socket head bolts.



Description	Part No.
Mikuni Super BN	59-9131

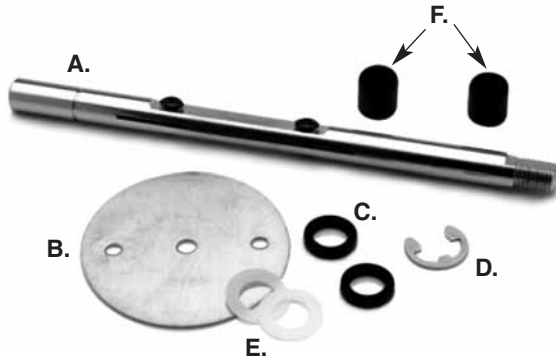

THROTTLE VALVE KIT

Description	Part No.	Mikuni Part No.
Throttle valve kit for 44mm	45	MK-BN/044 TV
Throttle valve kit for 46mm	46	MK-BN/046 TV
Throttle valve kit for 38mm	47	MK-BN/038 TV

THROTTLE SHAFTS AND VALVES

Description	Part No.	Mikuni Part No.
A. Super BN 44mm Throttle Shaft (Extended)	THS-4446	703-89004
B. Super BN 44mm #120 Throttle Valve	V44-120	BN44/06-120
B. Super BN 44mm #130 Throttle Valve	V44-130	BN44/06-130
B. Super BN 44mm #135 Throttle Valve	V44-135	BN44/06-135
B. Super BN 46mm #120 Throttle Valve	V46-120	818-46009-120
C. Super BN 38/44/46mm Throttle Shaft Seal	THSS	N167.126
D. Super BN 38/44/46mm Throttle Shaft Clip (Standard)	THSC	BN38/566
D. Super BN 38/44/46mm Throttle Shaft Clip (Heavy Duty)	THSCHD	MK-BN/005
E. Super BN 38/44/46mm Throttle Shaft Washer (Nylon)	THSW	N114.077
F. Super BN 38/44/46mm Throttle Shaft Bushing	49	BN38/569
Super BN 38/44/46mm Throttle Shaft Screw	THVS	

Super BN 38
Also used in late style Super BN 44

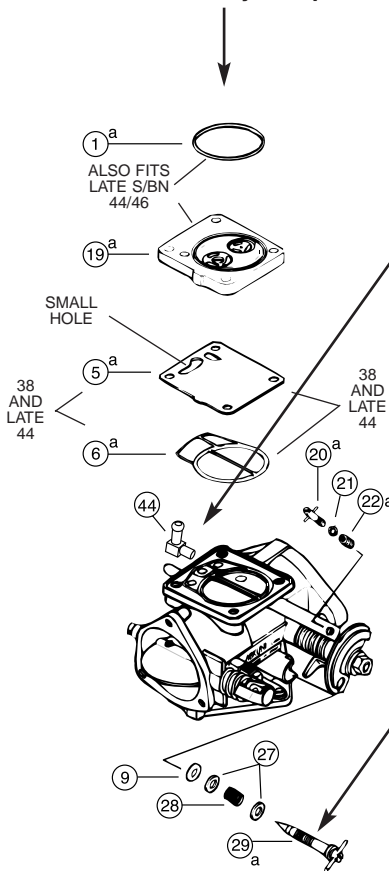

90° FUEL INLET FITTING (PRESS IN)

Description	Diag. #	Part No.
90° Fuel Inlet Fitting	44	DF44-2/70



ADJUSTER WITH CROSS BAR

Description	Diag. #	Part No.
High Speed 38/44	24	BN44/167
Low Speed 38	29a	BN38/477
Low Speed 44	29b	BN38/166

(Does not fit Yam OEM 44mm carb)



DIAPHRAGM AND FILTER

Description	Diag. #	Part No.
G. Diaphragm Assembly	16.	BN44/145
H. Super BN Filter	7.	BN44/146



ULTIMATE CARB GASKETS

Thick "Green" gaskets.

Mikuni	Part No.
38mm	9230
40mm "I" Series	9235
44mm	9240
46mm	9250
48mm	9252
50mm	9257
48mm SD951 I Series	6740

FUEL SYSTEMS
ENGINE/GASKETS
EXHAUST
DRIVE LINE HANDLING
ELECTRICAL
WATERLINE /BILGE
STEERING & CONTROLS
BODY
ACCESSORIES
SERVICE TOOLS /HARDWARE
CHEMICAL
FREESTYLE & 800SKR
FOUR STROKE



PARTS STAMPING This marking on a jetting part is your quality assurance guarantee it is a genuine Mikuni component. **DO NOT ACCEPT SUBSTITUTES.**



CARBURETOR JETS
Mikuni Low Jets
P/# (N100.606-size)

CARBURETOR JETS
Mikuni Main Jets
P/# (N102.221-size)

Size:	95	Size:	30	95	160
32.5	97.5	32.5	32.5	97.5	162.5
35	100	35	35	100	165
37.5	102.5	37.5	37.5	102.5	167.5
40	105	40	40	105	170
42.5	107.5	42.5	42.5	107.5	172.5
45	110	45	45	110	175
47.5	112.5	47.5	47.5	112.5	177.5
50	115	50	50	115	180
52.5	117.5	52.5	52.5	117.5	182.5
55	120	55	55	120	185
57.5	122.5	57.5	57.5	122.5	187.5
60	125	60	60	125	190
62.5	127.5	62.5	62.5	127.5	195
65	130	65	65	130	200
67.5	132.5	67.5	67.5	132.5	205
70	135	70	70	135	210
72.5	137.5	72.5	72.5	137.5	215
75	140	75	75	140	220
77.5	142.5	77.5	77.5	142.5	230
80	145	80	80	145	240
82.5	147.5	82.5	82.5	147.5	
85	150	85	85	150	
87.5	155	87.5	87.5	152.5	
90	160	90	90	155	
92.5		92.5	92.5	157.5	



GENUINE MIKUNI CARB COMPARTMENT KIT

Description	Part No.
Dealer Compartment Kit*	53-2120
Compartment only	53-2122

* Dealer Compartment Kit consists of:
4 Each of Needle and Seat 1.5/2.0/2.3/2.5
4 Each of Arm Spring 65/80/95/115gm
5 Each of Low Jets 67.5/70/72.5/75/77.5
 87.5/90/92.5/95/97.5/100/102.5/105/107.5/110
5 Each of Main Jets 105/110/115/120/125
 130/135/140/145/150/155/160

OLD TYPE NEEDLES & SEATS

**ROUND DIAPHRAGM COVER
STANDARD BN
OLD TYPE, STANDARD METAL TIP**

— Screw in Type —



Description	Part No.	Mikuni No.
1.5	53-2500	VM26/26-1.5
2.0	53-2501	VM26/26-2.0
2.3	53-2502	VM26/26-2.3
2.5	53-2503	VM26/26-2.5
2.8	53-2504	VM26/26-2.8

NEW TYPE NEEDLES & SEATS

SQUARE DIAPHRAGM COVER SUPER BN (NEW TYPE)

— Push in Type —



VITON TIP		
Description	Part No.	Mikuni No.
1.2	—	—
1.5	53-2600	786-35015-1.5
1.8	53-2608	786-35015-1.8
2.0	53-2601	786-35015-2.0
2.3	53-2602	786-35015-2.3
2.5	53-2603	786-35015-2.5

STANDARD METAL TIP		
Description	Part No.	Mikuni No.
1.2	53-2599	786-35018-1.2
1.5	53-2598	786-35018-1.5
1.8	53-2597	786-35018-1.8
2.0	53-2596	786-35018-2.0
2.3	53-2595	786-35018-2.3
2.5	53-2594	786-35018-2.5

MIKUNI ARM SPRINGS

POP-OFF PRESSURE CHART



Description	Part No.	Mikuni No.
65gm	53-2614	730-03030
80gm	53-2613	730-03033
95gm*	53-2615	730-03034
*This spring is for Sea Doo BN 46l Carbs Only!		
95gm	53-2612	730-03027-T
115gm	53-2611	730-03027

Part. No.	53-2611	53-2612	53-2613	53-2614
Arm Springs	115 grams	95 grams	80 grams	65 grams
Needle Valve Size	1.5	43 p.s.i.	38 p.s.i.	32 p.s.i.
	2.0	32 p.s.i.	25 p.s.i.	18 p.s.i.
	2.3	22 p.s.i.	20 p.s.i.	15 p.s.i.
	2.5	19 p.s.i.	17 p.s.i.	12 p.s.i.
Color	Gold	Dull Silver	Black	Shiny Silver

MIKUNI GENUINE PARTS

SUPER BN 46 "I"



SUPER BN 46 "I" TYPE CARB

Diagram No.	Description	Mikuni Part No.
4.	Grommet, Check Valve (2)	BN34/125
7.	Filter	BN44/146
8.	O-Ring, Hi Speed (2)	BN30/305
9.	O-Ring, Low Speed (2)	MD12/16
11.	Gasket Valve Body	BN34/123
12.	Check Valve (Clear)	BN34/107
14.	Pin, Arm	VM30/97
15.	Arm (Stainless)	BN38/534
16.	Diaphragm Assembly	BN44/145
61.	Gasket, Pump	BN46I/13
62.	Diaphragm, Pump (Clear)	BN46I/14
63.	O-Ring	616-73002
64.	Check Valve (2)	BN46I/11
66.	Diaphragm, Damper	BN46I/34
67.	Diaphragm, Damper (clear)	BN46I/15
68.	O-Ring	616-73003
69.	O-Ring, Needle Valve	KV/10

53-2115 BN46 I Rebuild Kit

21.	Washer, Aluminum (3)	BN38/39
25.	Spring (2)	BN38/344
27.	Washer, Aluminum (2)	BN38/172
28.	Spring, Low Speed	BN38/343
29b.	Adjuster, Low Speed	BN38/166
33.	Plate, Needle Valve Retainer	BN34/177-GG
34.	Screw with Washer	CW2-0307-G
37.	Screw	BV15/121-05-GG
38.	Plate, Valve	BN34/108-GG
39.	Valve Body Assembly	BN44/165
40.	Screw (2)	C5-0414-G
41.	Screw	C6-0308-G
42.	Cover (Stainless)	BN44/147
70.	Screw with 2 Washers (4)	BN34/120-35
73.	Stop Screw, Idle	BN38I/40
76.	Screw (4)	C2S=0514
77.	Diaphragm, Acclr. Pump	BN40I/22
79.	Body Assembly, Pump	BN46I/49



SA-300

SA-200

SA-100

ADJUSTER WITH CROSS BAR

This allows simple tuning adjustments, which is not possible with oem screw.

"I" series 44/46, OEM Yam GP800 & SD 951	Part No.
High Speed cross bar screw	SA-100

OEM Yamaha Carb, XL1200LTD, XLT1200, GP1200R	Part No.
Low Speed cross bar screw	SA-200
High Speed cross bar screw	SA-300

OEM Kawasaki Carb, Kawasaki 800SXR	Part No.
Low Speed cross bar screw	SA-500
High Speed cross bar screw	SA-100

OEM Yamaha Carb, Superjet 2004+	Part No.
Low Speed cross bar screw*	SA-700
High Speed cross bar screw*	SA-800

*Choke must be removed to install SA-700 and SA-800

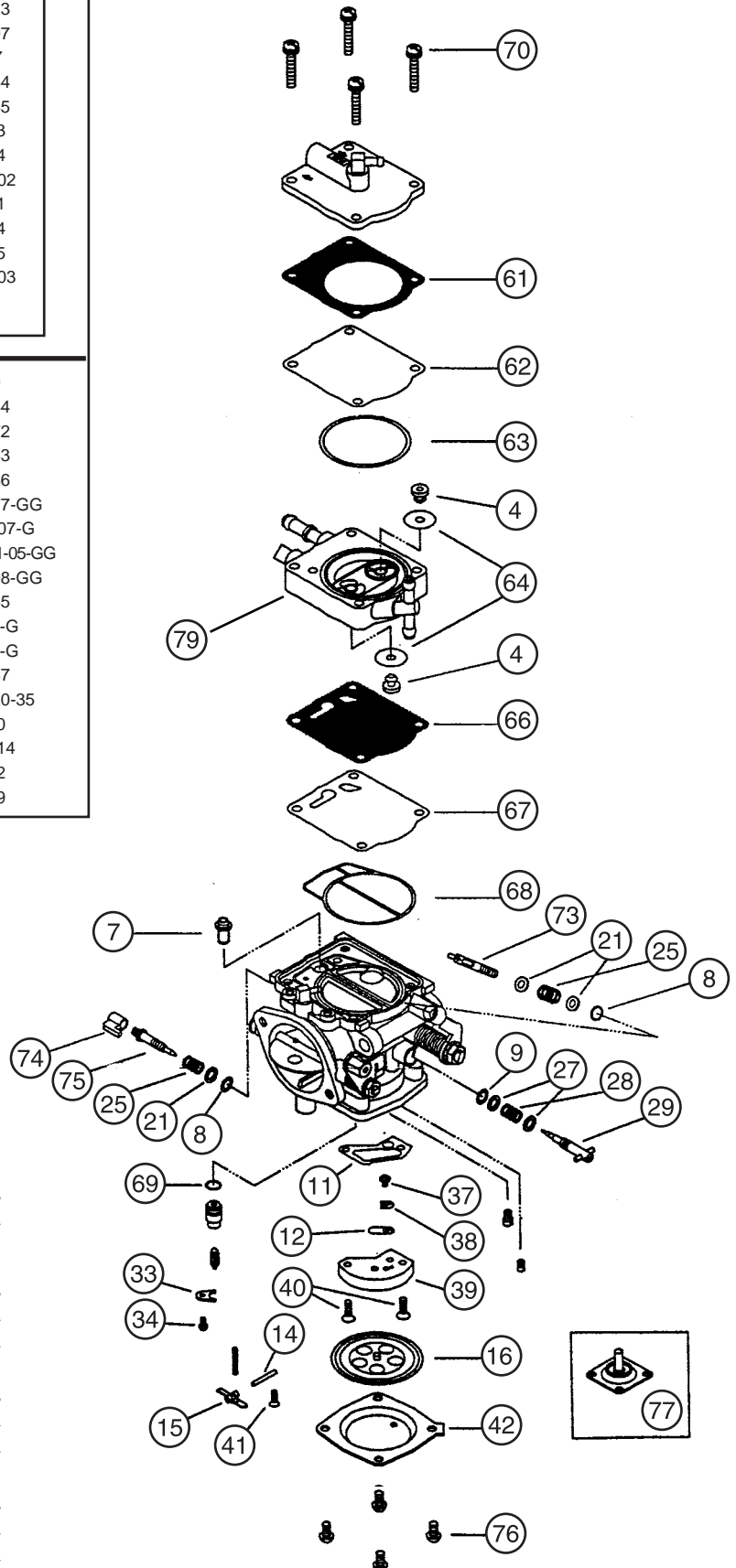

FUEL SYSTEMS
ENGINE/GASKETS
EXHAUST
DRIVE LINE HANDLING
ELECTRICAL
WATERLINE /BILGE
STEERING & CONTROLS
BODY
ACCESSORIES
SERVICE TOOLS
HARDWARE
CHEMICAL
FREESTYLE & 800SXR
FOUR STROKE

KEIHIN RACING CARBURETOR

FUEL SYSTEMS
ENGINE/GASKETS
EXHAUST
DRIVE LINE HANDLING
ELECTRICAL
WATERLINE /BILGE
STEERING & CONTROLS
BODY
ACCESSORIES
SERVICE TOOLS /HARDWARE
CHEMICAL
FREESTYLE & 800SXR
FOUR STROKE



KEIHIN OEM REPLACEMENT CARBURETOR

Polaris Hurricane 700
1996-97
39 mm

Description	Part No.
OEM Replacement	53-2030



KEIHIN FUEL PUMP REBUILD KIT

Includes all parts necessary to rebuild the Keihin fuel pump. Fits Kawasaki 650SX 1986-91, 650X2 1989-91.

Description	Part No.
Fuel Pump Rebuild Kit	53-2105

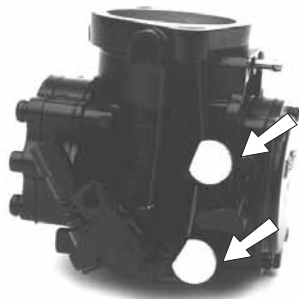

KEIHIN CARB MIXTURE ADJUSTMENT KNOBS

Billet aluminum, knurled outer, anodized knobs with index reference mark fit on the existing adjustment screws of Keihin 38/40mm carbs to make mixture adjustment easy.

Description	Part No.
Carburetor Adjustment Knobs	53-9993
Fits 38/40mm OEM Type only (does not fit 42mm)	



ULTIMATE CARB GASKETS

Thick "Green" gaskets.

Keihin	Part No.
38mm	9200
40mm	9205
42mm	9220



CARB SCREW ADJUSTING TOOL

A special 90-degree screwdriver, designed to adjust carburetors of triple-cylinder watercraft.

Description	Part No.
Carb Screw Adjusting Tool	53-9994

CARBURETOR JETS

Keihin Low Jets		Keihin Main Jets	Keihin Main Jets	
P/# (N424-35-size)		P/# (N424-27-size)	P/# (N424-36-size)	
40	88	150	100	155
42	90	155	102	158
45	92	160	105	160
48	95	165	108	162
50	98	170	110	165
52	100	175	112	168
55	102	180	115	170
58	105	185	118	172
60	108	190	120	175
62	110	195	122	178
65	112	200	125	180
68	115	(for CDCV)	128	182
70	118		130	185
72	120		132	190
75			135	195
78			138	200
80			140	
82			142	
85			145	
			148	
			150	
			152	

When ordering specify type and size. Part number is not necessary



2006 WORLD FINALS • LAKE HAVASU, AZ
PHOTO COURTESY OF JIN OMURA

**GENUINE KEIHIN
CARBURETOR PARTS**



Description	Diagram	Keihin Part No.
Screw	102	N114-03060
Adjust Screw (Main)	103	Z014-0660
Adjust Screw (Slow)	107	Z014-0670
Check Valve	110	1242-809-2000
Gasket	111	1202-823-2000
Cover	113	1230-827-2000
Diaphragm	114	1201-813-2100
Screw	115	93500-04008-1H
Coil Spring	116 A	1290-966-2000
Coil Spring	116 B	1290-947-2000
Screw	117	4114-001-1200
Arm Pin	118	16152-KG8-9010M1
Float Arm	119	1054-823-2000
Needle Valve	120	1062-818-2000
Gasket	121	1202-822-2000
U-Ring	123	0903-809-6000
Lever Pin	126	1480-049-2004
O-Ring	128	0901-055-6000
Screen	130	2009-811-2100
Diaphragm	134	1201-825-2000
O-Ring	137	0901-841-6000
Gasket	139	1202-851-2000

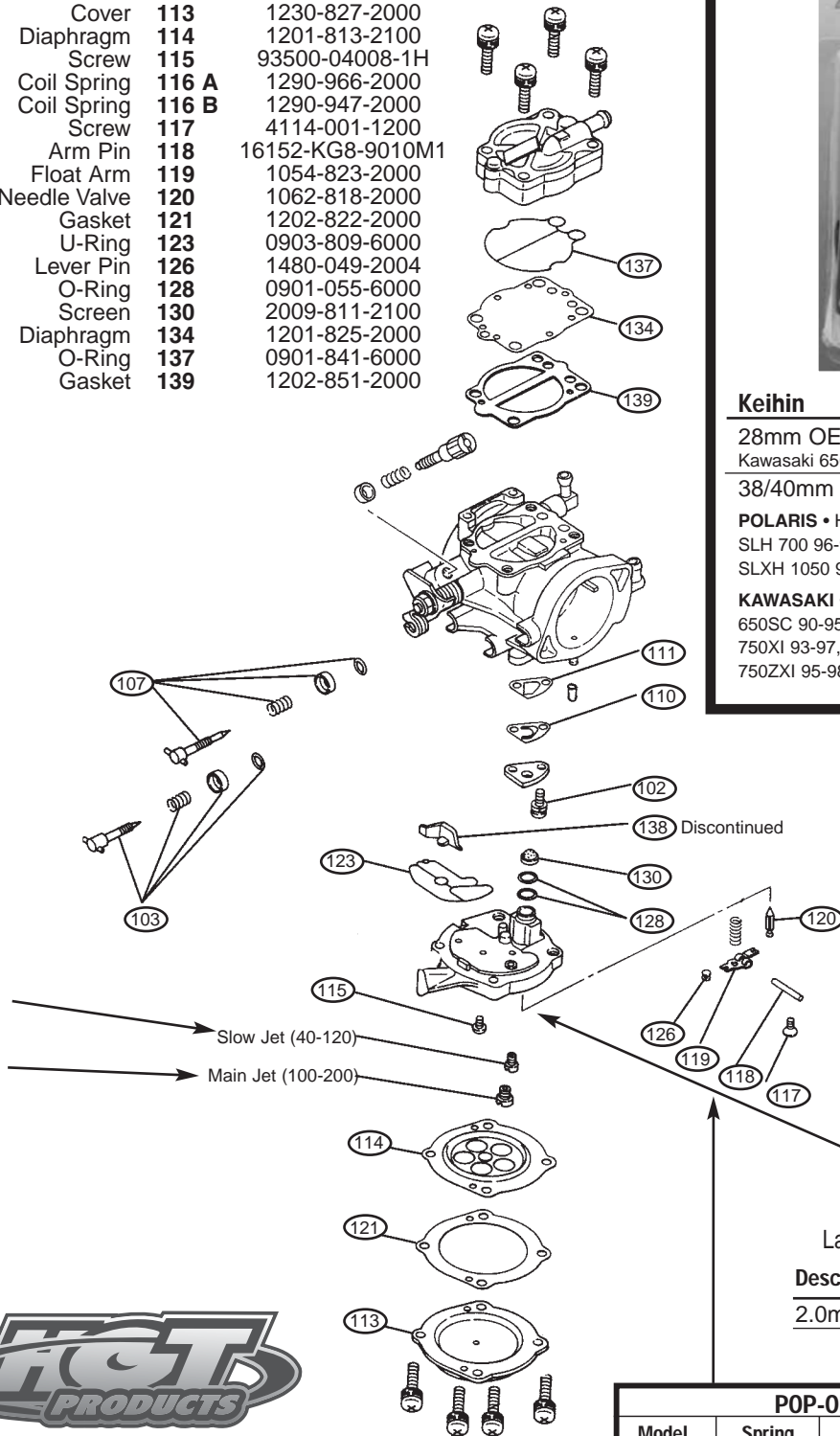

KEIHIN COIL SPRINGS

Description	Part No.
42mm 40 grm	1290-966-2000 116A
42mm 70 grm	1290-947-2000 116B
40mm 40 grm	1290-992-2000 116C
40mm 70 grm	1290-961-2000 116D

**KEIHIN GENUINE
CARBURETOR REBUILD KITS**

Kits include all necessary gaskets, diaphragms, and hardware required to disassemble and rebuild Keihin carburetor.



Keihin	Part No.
28mm OEM Type Kawasaki 650 SX 1986-91 & 650 X-2 1986-91	53-2100
38/40mm OEM Type & 42mm CDKII	53-2103

POLARIS • Hurricane 700 96-97, SL/SLT 700 96-97, SLH 700 96-97, SL900 96-97, SL/SLTX 1050 96-00, SLXH 1050 98-99, Genesis 99-00, 1200Pro 00, Virage/TX 00

KAWASAKI • JS440 91-92, JS550SX 91-95, 650TS 89-96, 650SC 90-95, 750SX 92-95, 750SXI 95, 750SS 92-98, 750XI 93-97, 750XIR 94, 750ST 94-95, 750STS 95-97, 750ZXI 95-98, 900ZXI 95-97, 900STX 97-99, 1100ZXI 96-97



**KEIHIN METERING BLOCK
ASSEMBLIES**

Large high flow needle valve seat assembly.

Description	Part No.
2.0mm	53-2609

POP-OFF PRESSURE CHART

Model	Spring Force	Spring Length	Part Number	Needle Valve	Valve Size
42mm CDK II	70gr.(std)	11mm	116B	24psi	18psi
	40gr.	9.17mm	116A	15psi	11psi
40mm mid range & 42mm Accp.	70gr.(std)	8.7mm	116D	N/A	N/A
	40gr.	7.4mm	116C	N/A	N/A

FUEL SYSTEMS	ENGINE/GASKETS	EXHAUST	DRIVE LINE HANDLING	ELECTRICAL	WATERLINE /BILGE	STEERING & CONTROLS	BODY	ACCESSORIES	SERVICE TOOLS	CHEMICAL	FREESTYLE & 800SKR	FOUR STROKE
--------------	----------------	---------	---------------------	------------	------------------	---------------------	------	-------------	---------------	----------	--------------------	-------------

BLACK CARBURETORS JACK

BLACKJACK HIGH FLOW PERFORMANCE CARBURETORS

The BlackJack Carburetor is a high flow performance carburetor designed to be user friendly. It uses a proven annular discharge design with modified internal circuits. BlackJack Carburetors are easy to tune and don't load up, even under extreme conditions. And BlackJack Carburetors product instant throttle response with more bottom end power, better mid-range acceleration, and unmatched top end.



Description	Part No.
44mm BlackJack	53-2092
46mm BlackJack	53-2093
48mm BlackJack	53-2094
48mm Butterfly only 12 Degree	48-012



RIVA YAMAHA RACING CARBURETOR WITH POWER BOMB FUEL ATOMIZER

Riva Yamaha new racing carburetors feature a short press fit air bell that tapers from a massive 70mm to a true 48mm throttle plate. Starting with proven Mikuni Super-BN carburetors, each one is hand assembled with top shelf components. At the heart of carburetor is Riva's exclusive "Power Bomb" fuel atomizer, providing peak performance under all conditions. Hesitation and bogging are eliminated while delivering explosive acceleration and extreme top speed. Available individually with flange mount or spigot mount.



Description	Part No.
48mm Flange Mount	RY1200R-48-IF
Butterfly Rebuild Kit	RY12-TSRK



DUAL CARBURETOR SYSTEMS

Sea Doo	Carb	Flame Arrestor	Part No.
720	Mikuni 44mm	K&N	53-0915
720	Mikuni 46mm	K&N	53-0916
800	Mikuni 44mm	K&N	53-0925
800	Mikuni 46mm	K&N	53-0926

720 Kits also fit 650 & 580 Engines. Please specify for proper jetting.



All carburetor kits are assembled with the above listed K&N Filters or Tau Ceti Pro Series II Flame Arrestors, the filter size and shape is the best fit based on the watercraft model.

FUEL SYSTEMS
ENGINE/GASKETS
EXHAUST
DRIVE LINE HANDLING
ELECTRICAL
WATERLINE /BILGE
STEERING & CONTROLS
BODY
ACCESSORIES
SERVICE TOOLS /HARDWARE
CHEMICAL
FREESTYLE & 800SXR
FOUR STROKE



HOT PRODUCTS CARBURETOR KITS

Yamaha	Carb	Flame Arrestor	Part No.
701 W/Rdr / 760 (62T)	Mikuni 44mm	K&N	53-0975
701 W/Rdr / 760 (62T)	Mikuni 46mm	K&N	53-0974
1100/1200	Mikuni 44mm	K&N	53-0980
1100/1200	Mikuni 46mm	K&N	53-0992

* See page 13 for crankcase application chart

Kawasaki	Carb	Flame Arrestor	Part No.
750	Mikuni 44mm	K&N	53-0830
750	Mikuni 46mm	K&N	53-0840

SINGLE CARBURETOR SYSTEMS

Kawasaki	Carb	Flame Arrestor	Part No.
650 SX/X2	Mikuni 44mm	K&N	53-0650
650 SX/X2	Mikuni 46mm	K&N	53-0660
750 All	Mikuni 44mm	K&N	53-0820
750 All	Mikuni 46mm	K&N	53-0825



All carburetor kits are assembled with the above listed K&N Filters or Tau Ceti Pro Series II Flame Arrestors, the filter size and shape is the best fit based on the watercraft model.

SINGLE INTAKE MANIFOLDS

FITS MIKUNI 44/46 MM

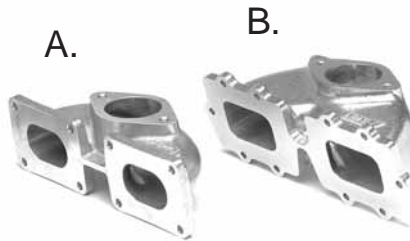

Kawasaki	Part No.
A. 650 All	53-0651
B. 750 All	53-0827



RIVA

Yamaha	Part No.
701/760 (62T/64X)	RY126M



FREE STYLE SINGLE INTAKE MANIFOLD ADAPTER KIT

This adapter makes a Kawasaki 650 single intake manifold fit on a Yamaha 701 case. Also ideal for Rental Yamaha watercraft for easy tuning.

Description	Part No.
Yamaha 701 Freestyle Intake Adapter Kit for Mikuni 44/46. Sold per set.	53-0652
Use with BCW Intake Manifold Part # 53-0651 listed above	

FUEL SYSTEMS
ENGINE/GASKETS
EXHAUST
DRIVE LINE HANDLING
ELECTRICAL
WATERLINE /BILGE
STEERING & CONTROLS
BODY
ACCESSORIES
SERVICE TOOLS /HARDWARE
CHEMICAL
FREESTYLE & 800SXR
FOUR STROKE

DUAL INTAKE MANIFOLDS FOR SEA DOO

FITS MIKUNI 44/46MM AND KEIHIN*



R&D

SEA D00	Part No.
580/650/720	53-0923



R&D

SEA D00	Part No.
XP800	223-80000

*Also fits Keihin



R&D

SEA D00	Part No.
XP800 Direct Flow	223-80001



R&D

SEA D00	Part No.
951	223-95000

Must use with part number 273-95000
R&D Stuffers

2006 WORLD FINALS
LAKE HAVASU, AZ

PHOTO COURTESY OF
JIN OMURA



DUAL / TRIPLE INTAKE MANIFOLDS FOR YAMAHA

FITS MIKUNI 44/46MM



Boyesen/Full Spectrum
Extream Velocity Manifold System



Reed cage
kit is not
included.



Yamaha	Part No.
701(62T)W/Rdr/760	IM001
Rad Reed Valve (See page 25 for details)	RAD-131R

Yamaha	Part No.
701(62T) W/Rdr/760 With Billet Carb. Plate for OEM Reed	222-76000
701(62T) W/Rdr/760 With Billet Carb. Plate for Moto Tassinari Reed	226-76100
Mounting Plate Gasket Center to center 120 mm	12-0010

Yamaha Crankcase Application Chart

6M6	650LX, VXR, Wave Runner III, Super Jet 90-93
61X	Pro VXR, Wave Runner III, GP, Super Jet 94-95, Fx-1, Wave Blaster 93-95, Raider 701 96-97
62T	Super Jet 96-01, Blaster II
64X	Wave Blaster 96-97, GP760, Raider 701/Deluxe/760 94-95, Venture 701/760, XL700/760
63M	Raider 1100, Venture 1100
66E	GP800 Power Valve
65U	GP1200, XL1200, SUV1200
66V	GP1200R, XL1200 LTD/XLT, 99-01 Power Valve



PRO-TEC

Yamaha **Part No.**
Y701 (62T), Wave Raider/760 **13-2109**



R&D

Yamaha **Part No.**
GP1200R/XLL-L **232-12100**
OEM/Mikuni w/Stuffer



R&D

Yamaha **Part No.**
GP800 with stuffers **222-80000**

DUAL / TRIPLE INTAKE MANIFOLDS FOR KAWASAKI FITS MIKUNI 44/46MM



R&D

Kawasaki **Part No.**
800SXR **231-75146**
With Billet Carb. Plate
for OEM Reed
Mounting Plate Gasket **12-0010**
Center to center 120mm



R&D

Kawasaki **Part No.**
800SXR **231-75148**
With Billet Carb. Plate
for MOTO TASSINARI reed
Mounting Plate Gasket **12-0010**
Center to center 120mm



Boyesen

• Kit includes (1) precision cast aluminum intake manifold, (2) "EV" RAD Valves, (1) carb adapter plate and all necessary installation hardware

Kawasaki **Part No.**
800 SX-R (03-07) **IM-002KIT**



R&D

Kawasaki **Part No.**
750 **231-75144**
Center to center 104mm



R&D

Kawasaki **Part No.**
800SXR for **231-75144-MT**
Moto Tassinari Reed



JetWorks

Kawasaki **Part No.**
Ultra 150/STX-R **53-0887**

*Sold separately *Use with OEM reed

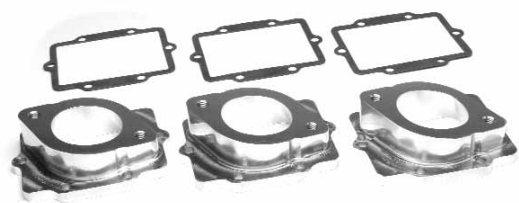

R&D

Kawasaki **Part No.**
Ultra 150/STX-R Kit **231-15000**

*Use with M-16 reed only

FUEL SYSTEMS
ENGINE/GASKETS
EXHAUST
DRIVE LINE HANDLING
ELECTRICAL
WATERLINE /BILGE
STEERING & CONTROLS
BODY
ACCESSORIES
SERVICE TOOLS /HARDWARE
CHEMICAL
FREESTYLE & 800SXR
FOUR STROKE



CARBURETORS LINKAGE

Linkage Kit	Part No.
Keihin	53-0602
Mikuni	53-0622
OEM Carb.	53-0628



CARBURETORS LINKAGE SLEEVES

Sleeve Only		Part No.
5/8"	16mm	53-9905
3/4"	19mm	53-9906
1"	25mm	53-9916
2-3/16"	56mm	53-9917
6"	152mm	53-9918



LINKAGE INSTALLATION TOOL FOR OEM CARB.

Description	Part No.
Linkage Installation Tool	53-0434



MIKUNI DUAL CARBURETORS LINKAGE KIT

Description	Part No.
Mikuni Dual Linkage Kit	MK-BN/001



JETWORKS LINKAGE

Using 120mm center to center aftermarket dual S/BN carburetor applications. It is made to have zero backlashes and will not compress after age.

Description	Part No.
120 mm center to center	LK-2



THROTTLE ARM LINKAGE & CONVERSION ARM

Description	Part No.
A. Throttle Arm (LH)	53-0611
B. Throttle Arm (Middle)	53-0612
C. Throttle Arm (RH)	53-0613

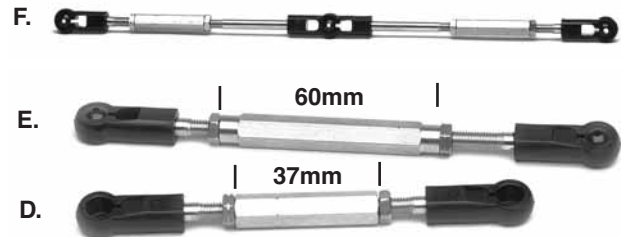

MIKUNI GENUINE OEM STYLE LINKAGE RODS

Description	Part No.
D. Sea Doo XP800	53-0615
E. Sea Doo 951	53-0616
F. Triple Carb Linkage Rod	53-0606



TBM CARBURETOR SHAFT COLLARS

Designed to replace the e-clips that commonly break allowing the carburetor shaft to vibrate side to side damaging the butterfly's and carburetor bodies. Manufactured from stainless steel for corrosion prevention, the two-piece design allows installation without disassembling the carburetors.

Description	Part No.
Carburetor shaft collars	TBM108



2006 WORLD FINALS • LAKE HAVASU, AZ
PHOTO COURTESY OF JIN OMURA

THROTTLE CABLE DRUM FOR MIKUNI

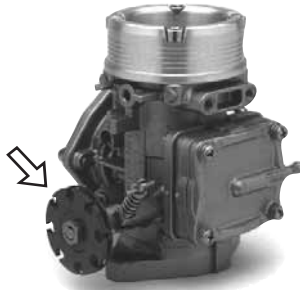

Hot Products original drum for Mikuni carburetors allows the use of any throttle cable and bracket on Mikuni carburetors. 8 positions, 18mm throw.

Description	Part No.
Hot Products Cable Drum 18mm Throw	53-2622

PJS Drums features a center web thin enough to allow use of nut with lock washer. "D" slot match the throttle shaft for a perfect fit. 12 positions and available in 20mm or 25mm throws

Description	Part No.
Standard Size (20mm throw)	53-2625
Oversized (25mm throw) For Oil injection and stock carburetors of Yamaha GP/XL	53-2627



THROTTLE CABLE BRACKETS FOR MIKUNI



Diaphragm Cover Mount Throttle Cable Bracket

Recommend for use with Hot Products Cable Drum Part #53-2622 8mm hole.

RY12-TCB	8mm
N-TCB-K	10mm



Body Mount Throttle Cable Bracket

53-3310

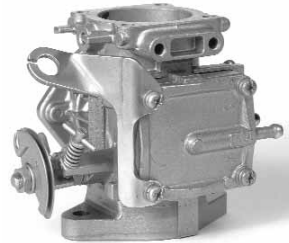

Kawasaki / Polaris / Tigershark - 10mm Hole

53-3317

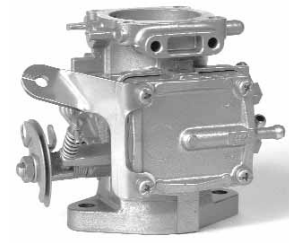

Sea Doo / Yamaha / WetJet - 8mm Hole

53-3318



MIKUNI SLOTTED CABLE DRUM FOR LINKAGE

Description	Part No.
Cable Drum	53-2628



MOTOINE SOFT SPRING FOR MIKUNI

New Motoine Mikuni spring is 2/3 softer than original spring and reduces thumb and/or finger throttle fatigue.

Description	Part No.
Soft Spring	MR-00013



2006 WORLD FINALS • LAKE HAVASU, AZ
PHOTO COURTESY OF JIN OMURA

FUEL SYSTEMS
ENGINE/GASKETS
EXHAUST
DRIVE LINE HANDLING
ELECTRICAL
WATERLINE /BILGE
STEERING & CONTROLS
BODY
ACCESSORIES /SERVICE TOOLS
HARDWARE
CHEMICAL
FREESTYLE & BOOSXR
FOUR STROKE



FUEL PICKUP FOR ZXI/STX-R

Provides maximum fuel flow to triple carbs

Description	Part No.
Kawasaki ZXI/STX-R	53-9957



ADA PICKUP FOR ULTRA

Description	Part No.
Kawasaki Ultra	KUPP



24-7 BILLET INTERNAL FUEL FILLER FOR YAMAHA SUPERJET

Description	Part No.
Dual Fuel Filler	DF-001
Single Fuel Filler	SF-001



BLOWSION FUEL FILLER FOR KAWASAKI SX/SXI/SXI-PRO/SXR

Description	Part No.
Billet Dual Pick Up	KASXAL 143



BLOWSION FUEL FILLER FOR YAMAHA SUPERJET AND POLARIS OCTANE

Description	Part No.
Billet Dual Pick Up	YAAMAL 140
Billet Single Pick Up	YAAMAL 141



BLOWSION RACING FUEL PICKUP FOR KAWASAKI SX/SXI/SXI-PRO/SXR

Description	Part No.
Billet Dual Pick Up	KASXAL144

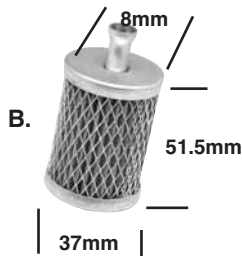
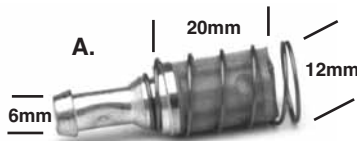

FUEL TANK FILTER

Description	Part No.
A. Universal Fuel Tank Filter (Replaces Sea Doo #275-500-005)	53-9946
B. Universal Fuel Tank Filter (Replaces Yamaha #8H5-224560-00)	006-516



ULTRA 250 DEEP FUEL PICKUP

The R&D deep fuel pickup is designed to maximize fuel volume. The Stock fuel pickup is located horizontally in the gas tank three inches above the bottom of the tank. This leaves approximately 5 gallons of unusable fuel in the tank. The R&D deep fuel pickup relocates the stock fuel pickup to the bottom of the tank in a vertical position. The new position allows for 24 percent more riding time per tank of gas.

An absolute must for offshore racing.

Description	Part No.
Deep Fuel Pickup	801-25100



ONE WAY CHECK VALVE

One way vent valve allows fuel to travel in one direction only. 1/4" Fuel Line.

Description	Part No.
One Way Check Valve	53-9941



RIVA HIGH VOLUME FILTER

3/8" Fuel Line.

Description	Part No.
3/8" Riva High Volume Filter	RY-0503



2" SLIMLINE WITH BRONZE ELEMENT

Clear nylon housing and bronze 75 Micron Element. 2" length. 1/4" Fuel Line.

Description	Part No.
2" Slimline with bronze	53-9952
Retail sales display card with 20 filters	53-9952D



3" SLIMLINE WITH POLYESTER ELEMENT

Lightweight high flow 90 Micron Polyester Element. 3" length. 1/4" Fuel Line.

Description	Part No.
3" Slimline with polyester	53-9953
Retail sales display card with 20 filters	53-9953D



IN-LINE OIL FILTER

75 Micron Stainless Steel Element. 1.3" diameter, 1/4" Fuel Line. This filter works with fuel and oils. Perfect protection for oil pumps and oil injection engines.

Description	Part No.
Stainless Steel filter	53-9943
Retail sales display card with 20 filters	53-9943D



HIGH-CAPACITY HIGH FLOW FILTER

80 Micron Paper Element. 1.6" diameter, 1/4" Fuel Line.

Description	Part No.
High Flow Paper Filter	53-9945
Retail sales display card with 20 filters	53-9945D



HIGH PERFORMANCE CATALYTIC FILTER

A Fuel filter made of high impact nylon. Clean burning engines, better throttle response and some increase in power and fuel efficiency.

Description	Part No.
Catalytic Filter	53-9948



QUICK DISCONNECT RESTRICTOR

Mikuni main jets thread into the billet part of the restrictor. This kit is used on the return lines of carburetors to fine tune fuel pump pressures.

Description	Part No.
Quick Disconnect Restrictor 1/4"	QD-14



Recommended Main Jets:

Stock Carbs for 1200 (66V) 105
 Novi Carbs for 1200 (66V) 100-120
 Novi Carbs for 701 (61X) 100-120

FUEL RETURN LINE RESTRICTOR

Designed to improve throttle response and reduce lean conditions in power band, our new Fuel Return Line Restrictor installs into fuel return line between carburetors and fuel tank, restricting fuel return rate, increasing pressure to carburetors. Precision-machined billet restrictor is threaded to accept a Mikuni Main Jet (not included) to match your application. For use with OEM and aftermarket carburetors.

Description	Part No.
Fuel Return Line Restrictor	RY12-RLR-14



RIVA FUEL FILTERS

OE replacements fit stock mounting bracket in all Yamaha watercraft these fuel filters also serve as a water separator protecting the motor from water damage

Description	Part No.
OE Replacement filter (all except 66V/E)	RY-0501
OE Replacement filter 66V/E	RY-0502

FUEL SYSTEMS
ENGINE/GASKETS
EXHAUST
DRIVE LINE HANDLING
ELECTRICAL
WATERLINE /BILGE
STEERING & CONTROLS
BODY
ACCESSORIES
SERVICE TOOLS /HARDWARE
CHEMICAL
FREESTYLE & 800SKR
FOUR STROKE



1/4" FUEL LINE & 1/8" PRIMER LINE

Our fuel and primer line is made from a thick walled polyurethane tubing. Both fuel and primer line is blue. Sold per foot, or 25 feet/pk.

Description	Part No.
Fuel (1/4") per foot	53-9970
Fuel (1/4") 25 feet/pk	53-9970-25
Primer Line (1/8") per foot	53-9980
Primer Line (1/8") 25 feet/pk	53-9980-25



PRIMER LINE

Double layer constructed fuel hose for primer. Made in Japan. Sold in 25 feet/pk

Description	Part No.
Primer Line (I.D. 3mm/O.D. 7mm)	53-9985

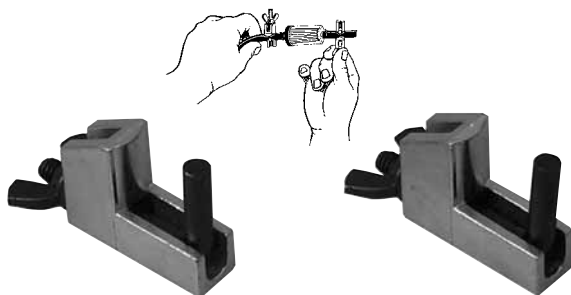

HOSE PINCHERS

Quick, easy way to pinch off fuel lines, etc, without damaging the fuel line. Sold two per set.

Description	Part No.
Hose Pinchers	LS22850



FUEL FEED AND VENT HOSE

Designed to meet fuel hose specifications of SAE J1527 and ISO 7840. The barrier construction provides the lowest permeation rating available for any marine fuel hose. Formulated to handle gasoline, diesel and alcohol blended fuels. This hose meets all the requirements of the USCG, NMMA, ABYC and is certified by IMCI for use in the European community. The 360 series is an A-1 hose that can be used in a feed or vent application. The flame resistant cover is designed for enclosed engine compartment applications.

* Recommended to use with "squeeze on" clamp P/#59-4017

Description	Part No.
1/4" Fuel Feed & Vent Hose 25 feet/pk.	360-014



SQUEEZE ON STAINLESS STEEL CLAMPS

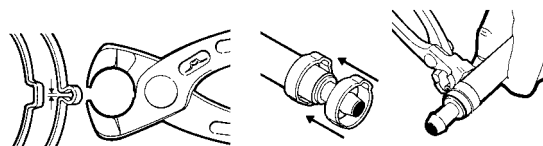

Description	Clamp Size	Part No.
Pincer Tool		59-4015
Clamp for 1/4" Hose (10 pcs/pk)	9/16	59-4016
Clamp for 3/8" Water Line (10 pcs/pk)	11/16	59-4017
Clamp for 1/2" Water Line (10 pcs/pk)	13/16	59-4018



FUEL LINE Q/D W/SHUT-OFF VALVE for 1/4" fuel line

Description	Part No.
Fuel Line Q/D w/Shut-off Valve	53-9951



PRIMER KITS

A cure for hard-starting motors. Draws fuel from the fuel line to give the carburetor a blast of fuel for easy starting. Eliminates chokes and adds to battery life. A must on high-performance modified carburetors with eliminated chokes. Hot Products primers are assembled with top-quality materials and include 9 feet of 1/8" blue primer hose to fit sit down craft. USA made top-quality plunger, brass "T" fittings, spigot, caps and zip ties.

Plunger Primer Kit	Part No.
Mikuni Primer Kit Single	53-9920
Mikuni Primer Kit Dual	53-9928
Mikuni Primer Kit Triple	53-9922
Keihin Primer Kit Single	53-9925
Keihin Primer Kit Dual	53-9929
Keihin Primer Kit Triple	53-9924

MIKUNI

KEIHIN



Spigot & Cap Kit

Brass T Fitting

Parts Only	Part No.
G. Mikuni Brass Spigot & Cap Kit	53-9921
Mikuni Brass Cap Only	53-9921B
H. Keihin Brass Spigot & Cap Kit	53-9926
Keihin Brass Cap Only	53-9926B
I. Brass T for Dual 1/8" x 1/8" x 1/8"	64-0015
J. Brass T for Primer 1/4" x 1/4" x 1/8"	64-0017
Primer Line 1/8" (Sold per foot)	53-9980

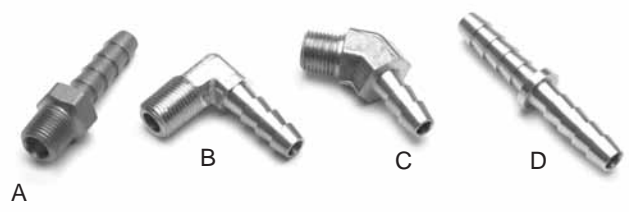

1/4" HOSE BRASS FITTINGS

Description	Part No.
A. Straight: 1/8" Thread 1/4" Hose	64-0001
B. 90 Degree: 1/8" Thread 1/4" Hose	64-0010
C. 45 Degree: 1/8" Thread 1/4" Hose	64-0065
D. Barb Connector 1/4" I.D.-1/4" I.D.	64-0057



PRIMER ADD ON KITS

Mikuni and Keihin primer add on kits for use with dual and triple carb kits. One add on kit needed for duals, two needed for triples. Kit includes spigot and cap, T-fitting, 6" of 1/8" blue primer hose and zip ties.

Description	Part No.
Mikuni Primer Add On	53-9923
Keihin Primer Add On	53-9927



53-9915



53-9910A

Plunger Body Only	Part No.
Plunger Primer Only	53-9910A
Button Primer Only	53-9915



PRESS IN NIPPLE

Description	Part No.
1/8" Straight	53-9936
1/4" Straight	53-9937



PLASTIC "Y" FITTINGS

Description	Part No.
1/4" X 1/4" X 1/4" (White)	64-0046
1/4" X 1/4" X 1/4" (Black)	64-0047



MIKUNI HIGH VOLUME FUEL PUMP

16 gallons/61 Liters per hour

Description	Part No.
Fuel Pump	53-3328
Fuel Pump Repair Kit	53-3328RP



**Fuel pump is not included

CARBON REMOTE FUEL PUMP BRACKET

Use this ultra sano 100% carbon fuel pump bracket when adding remote fuel pumps. Lightweight and burly, this is the key to your mounting problems without adding weight or stress to the engine compartment.

Description	Part No.
Fuel Pump Bracket	KASRCO426



2006 WORLD FINALS • LAKE HAVASU, AZ
PHOTO COURTESY OF JIN OMURA



SPIGOT MOUNT FLANGE FOR MIKUNI CARBURETOR

Description	Part No.
I-VM40-200-1 (Gold Band)	48
I-VM44-200-1 For Sea Doo 951 (Black band)	53

For easier removal and installation of carburetor for jetting and maintenance. Recommended to use with side draft manifold only.



SEA DOO DUAL FUEL PUMP UPGRADE KIT

A must for high performance engines with the OEM dual carbs with a single fuel pump. Kit adds a fuel pump to the rear carb, eliminating fuel starvation in the rear carb at high RPM. Includes pulse fitting and hose.

Description	Part No.
Sea Doo Fuel Pump Kit	53-3325



KEIHIN CARBURETOR ADAPTERS FOR MIKUNI CARBURETOR MANIFOLDS

Description	Part No.
A. This adapter allows mounting of Keihin CDKII 38, 42 carburetor to any popular O.E. or aftermarket 44mm Mikuni intake manifold.	53-3305

*The carb will stand straight up when using this adapter - the carb is just rotated a few degrees to clear the adapter mounting bolts.

Description	Part No.
B. This adapter is designed to mount to the Keihin CDKII 38, 42 carburetor at an angle specifically for the Kawasaki JS440/550 piston port engine.	53-3308

*A short air filter is required for to prevent rubbing on the inside of the hood



MIKUNI PUMP BLOCK OFF

Absolutely necessary tool to get your set-up perfect. Eliminates guesswork and wasted time. For all brands.

Description	Part No.
Pump Block Off	53-3330



HOT CARB HOLDER PLUGS

Description	Part No.
9/32" Sold in PK/10 pcs Universal plastic plug has many uses	53-9938



BILLET ALUMINUM OIL INJECTION BLOCK OFF



Polaris	Part No.
SL/SLT650/750SLX/SL SLT780 (Comes w/ case plug), SLX Pro 785	50-9502
SL700/SLT700/Hurricane SL900/SLTX/1050 (Oil injection plug only)	50-9509



Sea Doo	Part No.
580/650/720 All	50-9504



Sea Doo	Part No.
800/951	50-9506



Yamaha	Part No.
650/701/760	50-9500



Yamaha	Part No.
1100/1200/ GPR	50-9501

Kawasaki	Part No.
650/750	50-9500

Kawasaki	Part No.
900/1100	50-9503



PLASTIC CAPS

Caps are sold in packs of 10.

Plastic Caps	Part No.
Small 1/8"	50-9500P
Large 3/8"	50-9504P



CASE BLOCK OFF

Kawasaki	Part No.
650/750	50-9505

*Case Block off not applicable for 800SXR

ROTARY VALVE PARTS

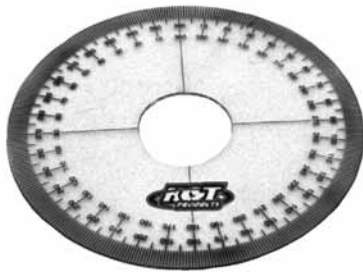
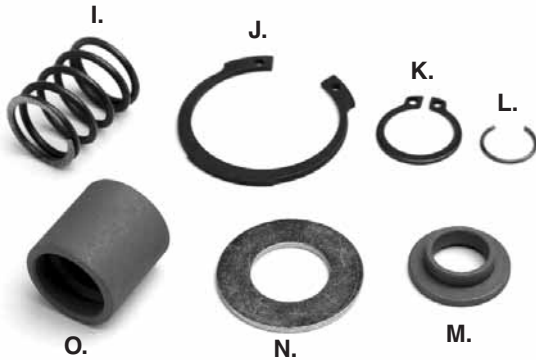
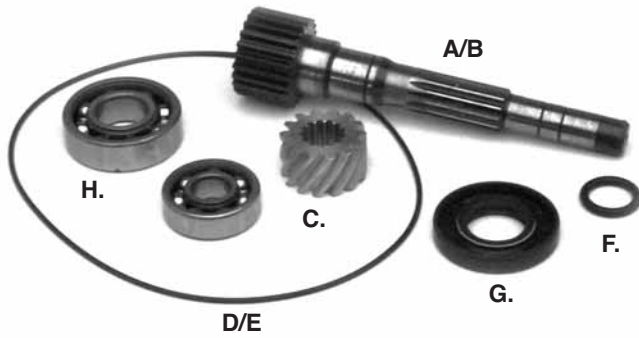

ROTARY VALVE TIMING WHEEL

Description	Part No.
Rotary Valve Timing Wheel	012-170



ROTARY SHAFT PULLER

Special rotary shaft puller tool for Sea Doo PWC.
 Fits: Most 580cc, 650cc, 720cc, and 800cc Sea Doo engines.
 (6mm thru bolt included)
**Lubrication of all areas is required before using this tool*

Sea Doo	Part No.
Rotary Shaft Puller	B-204

SEA DOO ROTARY VALVE SHAFT AND PARTS

Descriptions	OEM#	Part No.
A. Rotary Valve Shaft 580/650/720	293-837-251	010-455
B. Rotary Valve Shaft 800	290-837-351	010-457
C. Rotary Valve Shaft Gear only (14 teeth) 580/650/720/800 (89-up)	420-935-735	010-450
D. Rotary Cover O-Ring 580/650/720	293-300-023	6250
E. Rotary Cover O-Ring 800	290-831-765	6628
F. Rotary Shaft O-Ring 580/650/720/800	293-300-024	6260
G. Rotary Shaft Oil Seal 580/650/720/800	290-930-580	009-779
H. Rotary Shaft Bearing 580/650/720/800	290-932-032 290-932-797	010-225 010-226

Descriptions	OEM#	Part No.
I. Rotary Shaft Spring 580/650/720/800	290-938-810	010-453
J. Rotary Shaft Snap Ring	290-845-260	010-483
K. 580/650/720/800	290-932-032	010-482
L. Rotary Shaft C-Clips 580/650/720/800	290-845-160	010-454
M. Rotary Spring Holder 580/650/720/800	420-827-430	010-484-01
N. Rotary Bearing Washer 580/650/720/800	420-227-439	010-459
O. Rotary Shaft Barrel 580/650/720/800	290-847-282	010-484

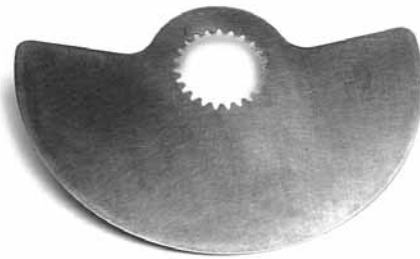

STAINLESS STEEL ROTARY VALVES

Model	Year	Opening Duration	Part No.
580 All	94-96	147°	006-147
650 All	94-95	159°	006-159
720	95-02	159°	006-159
785	95-02	159°	006-159



2006 WORLD FINALS • LAKE HAVASU, AZ
 PHOTO COURTESY OF JIN OMURA

Boyesen



BOYESEN POWER REEDS

- The unique dual-petal design
- Quicker acceleration, throttle response and speed.
- Dual-flex epoxy fiber material for maximum longevity and reliability.

Yamaha	Part No.
500 All	022
650 Super Jet	023
650 Wave Runner (All)	023
700 Wave Raider All	024
701 FX1 (94-95)	024
701 Pro-VXR (93-94)	024
701 Super Jet (94-95)	024
Wave Blaster (93-95)	024
Wave Raider (Single Carb) (96)	024
Wave Runner III (94-97)	024
701 Super Jet (96-07)	026
Wave Blaster (96)	026
Wave Raider (94-96)	026
Wave Raider DLX (95-96)	026
Wave Runner XL (99-02)	026
Wave Venture (95-98)	026
GP760(97-00), 760 Waves All (95-99)	029
1100 All (95-97)	028
GP1200(97-99), SUV1200(99-02)	033
XL1200(98)	033

Kawasaki	Part No.
550SX (91-95)	014
650SX/X2/SC/SS/ST/TS All	012
750SX/SXI/SXI-Pro All	013
750SS/STS/XI/ZXI All	013
800 SX-R (03-07)	013
900ZXI(97), STX(97-01), STS(01)	020
1100ZXI/STX/DI(96-01)	021
Ultra 130(01)	036
STX-R 1200 (02), Ultra 150 (99-05)	021

Polaris	Part No.
650 All (92-95)	016
SL750(93-95), SLT750(94-95)	016
SL780(96-97), SLT780(96-97)	016
SLT780(96-97), SLX780(96)	016
SLX785 Pro (97-02)	016
700 All (-02)	013
Octane (02-04)	013
800 DI (02-04)	013
Hurricane (96-97)	013
SL900(96-97)	030
SL1050(97), SLTX1050(96-99)	031
SLX1050(98)	031
Pro/SLX/Virage TX 1200(00-02)	031
Genesis 1200/FFI (99-01)	031
MSX 140 (03-04)	031

Tigershark	Part No.
640 All (93-99), 770 All (96-99)	018
900 (95-96)	019
1000 All (97-98), TS1100 (99)	019



BOYESEN PRO SERIES REEDS

- Quicker acceleration for that all important holeshoot.
- Crisper mid-range allowing you to pull that extra boat length.
- Carries RPMs further past peak allowing you to run that steeper pitched impeller for increased top end.
- Easy starting and smoother idling for those dreaded no-wake zones.
- Increased life over traditional carbon fiber reeds.

Yamaha	Stock Unlimited	Hi-Performance
700 Wave Raider All	PRO-34	PRO-35
701 FX1 (94-95)	PRO-34	PRO-35
701 Pro-VXR (93-94)	PRO-34	PRO-35
701 Super Jet (94-95)	PRO-34	PRO-35
701 Super Jet (96-07)	PRO-36	PRO-37
Wave Blaster (93-95)	PRO-36	PRO-37
Wave Blaster (96)	PRO-36	PRO-37
Wave Raider (94-96)	PRO-36	PRO-37
Wave Raider, Single Carb (96)	PRO-34	PRO-35
Wave Raider DLX	PRO-36	PRO-37
Wave Runner III (94-97)	PRO-34	PRO-35
Wave Runner XL (99-02)	PRO-36	PRO-37
Wave Venture (95-98)	PRO-36	PRO-37
GP760 (97-00)	PRO-38	PRO-39
760 Waves All (96-99)	PRO-38	PRO-39
1100 All (95-97)	PRO-40	PRO-41
GP1200(97-99)	PRO-77	PRO-78
SUV1200(99-02), XL1200(98)	PRO-77	PRO-78

Kawasaki	Stock Unlimited	Hi-Performance
750 All	PRO-24	PRO-25
800 SX-R (03-07)	PRO-24	PRO-25
900 All	PRO-76	—
1100 All (96-02)	PRO-57	—
Ultra 150/STX-R1200 (99-05)	PRO-57	—

Polaris	Stock Unlimited	Hi-Performance
700 All (-02)	PRO-26	PRO-27
Octane	PRO-26	PRO-27
750 All (93-95)	PRO-28	PRO-29
780 All (98-97)	PRO-30	PRO-31
785 SLX Pro (97-02)	PRO-30	PRO-31



FUEL SYSTEMS
ENGINE/GASKETS
EXHAUST
DRIVE LINE HANDLING
ELECTRICAL
WATERLINE /BILGE
STEERING & CONTROLS
BODY
ACCESSORIES
SERVICE TOOLS /HARDWARE
CHEMICAL
FREESTYLE & 800SKR
FOUR STROKE



Carbon Tech

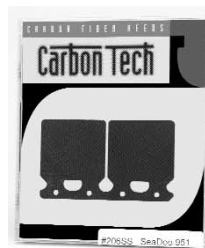

FUEL SYSTEMS

ENGINE/GASKETS

EXHAUST

DRIVE LINE HANDLING

ELECTRICAL

WATERLINE /BILGE

STEERING & CONTROLS

BODY

ACCESSORIES

SERVICE TOOLS /HARDWARE

CHEMICAL

FREESTYLE & 800SXR

FOUR STROKE

Sea Doo

CC	Model	Year	Performance Info	Part No.
951	All 951 models	97-06	Better mid & top end for stock, limited and superstock motors: +4hp midrange,+2 top 206HT Highly modified motors for top end only	206SS OR 206HT

Polaris

CC	Model	Year	Performance Info	Part No.
650	All 650 models	92-95	Better low to mid	317LT
700	All 700 models	96-04	Better bottom and midrange	275LT
750	All 750 models	93-95	Better mid (used by factory riders)	317LT
777	Octane	02-04	Better low to mid/stock, limited	275LT
	Virage I	02-04	Better mid to top for superstock	275MT
780	All 780 models	96-97	Better low to mid	317LT
780	SLX Pro 785	97-00	Best low to mid	317LT
			Best mid to top end: most durable	317HT
900	SL900	96-97	Increased rpm for higher top spd.	318LT
1050	All 1050 models	96-99	Increased rpm for higher top spd.	318LT
1165	All 1200 models	99-04	318LT More low end response	318LT or
			318HT Mid to top end: most durable	318HT
1192	MSX 140	03-04	More low end response	318LT
			Mid to top end: most durable	318HT

Yamaha

CC	Model	Year	Performance Info	Part No.
650	All 650 models	89-96	Smother powerband	223LT
701	Wave blaster	93-95	225LT Stock cylinder, single carb.	225LT
with	Superjet	94-95	225HT Sock cylinder, dual carbs	225HT
61X	FXI	94-95		or
CASE	PROVXR	93-94	225M Ported motors, single carb.	225M
	Waverunner III	94-95,97	225SS Ported motors, dual carbs	225SS
	Waveraider	96-97		
701	Waveraider	94-95		
with	Waveblaster	96	202LT +3HP in midrange: for limited and stock motors	202LT
62T	Superjet	96-06		or
CASE	Wave Venture	95-98	202SSKT Special kit for superstock applications	202SSKT
	XL 700	99-04		
760	All 760 Models	96-00	202LT +3 HP in mid, +2HP top end for limited and non-ported rec boats	202LT
			202HT Best choice for 760 superstock motors or fuel injected 701 motors	202HT
800	GP800	98-00	Better midrange & top end for stock	266HT
	GP800R	01-05	Limited & superstock motors: Gives 100 RPM=1 MPH	
	XL/XLT 800	00-04	(tested by Pro-Tec)	
1100	All 1100 models	95-97	Better midrange	302LT
1131	GP1200	97-99	*+3 HP mid to top: limited racing	338LT
	XL1200	98-99	Superstock & recreational motors	338SS
	SUV1200	99-04	Top end: only choice for fuel Ing.	338HT
1176	XL1200ltd	99-00	Stock motors, single pipe motors	366HT
	XLT1200	01-05	Single pipe, limited triple pipe	366SS
	GP11200R	00-02	Ported triple pipe motors	366R
1296	GP1300R	03-06	Stock motors, single pipe motors	366HT
			Single pipe, limited triple pipe	366SS
			Ported triple pipe motors	366R

Kawasaki

CC	Model	Year	Performance Info	Part No.
550	ALL	91-95	Smother powerband	239LT
650	ALL	86-96	Improved low to midrange	212LT
743	ALL	92-02	Better low & mid: stock & limiteds	238LT
			Superstock & ported motors	238SS
			High RPM, stroked or fuel injected	238HT
782	800 Motor	03-06	Better low & mid: stock & limiteds	238LT
			Superstock & ported motors	238SS
			High RPM stroked or fuel injected	238HT
891	ALL 900 MOTORS	95-06	Better midrange and bottom end	338LT
			Superstock & ported motors	338SS
1071	ALL 1100 MOTORS	96-04	Better low & mid: stock & limiteds	338LT
			Superstock & ported motors	338SS
			High RPM, stroked or fuel injected	338HT
1176	Ultra 150	99-05		338LT, 338SS
	1200STXR	04-05		or 338HT



NEW V-FORCE DELTA 2

	Delta 2	Delta 2 Repl. Pedal	Delta 1 Repl. Pedal (97-99)	Delta 2 Repl. Gasket
Sea Doo	Delta 2			
GSX/GTX/XP 951*	V2W121-2	2P127-1	DP120-1	6755

Polaris

SL650,SL/SLT750				
SLX780/785 Pro	V2W131-3	2P117-1		4050
SL900/SLTX1050	V2W132-3	2P117-1		4050
Octane 777	V3130-794A-2	3P794A-1		

Yamaha

All Triples	V2W140-3	2P127-1	DP120-1	4430
All Twins**	V2W140-2	2P127-1	DP120-1	2830

Kawasaki

All Triples	V2W150-3	2P127-1	DP120-1	MT6150
All Twins	V2W150-2	2P127-1	DP120-1	MT6150

*must use with part #53-0939 R&D Manifold

**except older Blasters



- Sold as complete system per engine.
- Replacement pedals and gasket: sold one set for each reed valve.

The V-Force reed valve has been the first choice of watercraft racers everywhere. Many of the top teams and racers depend on the extra performance of the V-Force Reed Valve System. One of the major benefits of our reed valve is the huge improvement in throttle response. In a sport where holeshots and quick acceleration make the difference between winning and losing, the V-Force is a huge advantage! Due to the increased airflow of a V-Force Reed Valve System there is a very tangible increase in overall responsiveness. A sample of the racers and teams that rely on V-Force are... Team Riva Yamaha. Team Factory Kawasaki, Tera Crismon, Factory Sea-Doo, Alia Jones and many more.



RAD VALVES FOR YAMAHA WATERCRAFT



	Replacement Rad Valve	Replacement Rad Reed	Gasket
Yamaha 701(62T)/760(64X)/1100(63M)/1200(65U)	RAD-131*	PRO-131	2830
Stock Intake Manifold in Stock applications	RAD-131R*	PRO-131R	2830
Riva or R&D Twin or Triple Intake Manifold	RAD-131R*	PRO-131R	2830

Yamaha 701(62T) ONLY

Use with Boyesen/Full Spectrum Extream

Velocity Manifold System p/# IM001 (page 13)	RAD-131A**	RL 131A	2830
--	------------	---------	------

* Order one set per cylinder, 2 valves for twin, 3 valves for triple cylinders.

** This kit contains 2 valves for 701 cylinders.



BOYESEN REED VALVE STUFFER KIT

Yamaha	Part No.
GP1200R (00-02), XL/XLT 1200 (99-05), GP1300R (03-07)	RSK-306
Replacement Reed *Must use with Boyesen Stuffer	PRO-128

- Kit includes a complete engine set of Boyesen 3D Reed Valve Stuffers and Boyesen PRO Series reeds

FUEL SYSTEMS	ENGINE/GASKETS	EXHAUST	DRIVE LINE HANDLING	ELECTRICAL	WATERLINE /BILGE	STEERING & CONTROLS	BODY	ACCESSORIES	SERVICE TOOLS	CHEMICAL	FREESTYLE & 800SXR	FOUR STROKE
--------------	----------------	---------	---------------------	------------	------------------	---------------------	------	-------------	---------------	----------	--------------------	-------------

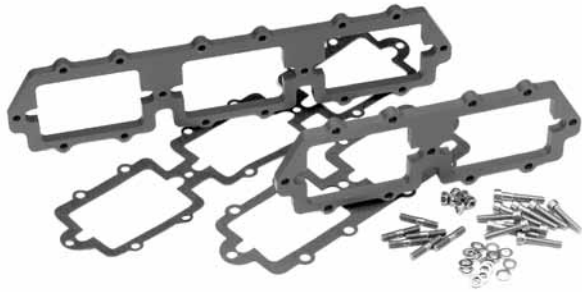

REED VALVE SPACER BOOSTERS

Yamaha	Part No.
701/760 (62T/64X) Case	RY124M-S
701/760 Spacer Gasket	53-5235-GSK
1100/1200 (63M/65U) Case	RY128M-S
1100/1200 Spacer Gasket	53-5236-GSK



R&D REED VALVE SPACERS

Yamaha	Part No.
701/760 (62T/64X) Reed Spacer Angled	262-70101



JSU ANGLED REED SPACER

Angled to direct intake airflow up into the transfer ports on cylinder. This reed spacer kit is the easiest way to bolt on a 3 HP gain. Kit comes complete with all the hardware and gasket needed for installation.

Kawasaki	Part No.
K750/800SXR Angled Reed Spacer	JSU 800-RSK



SEA DOO REED VALVE SPACERS

Improve low end/mid-range response, torque and horsepower.

Sea Doo	Part No.
951 ALL	53-5239



*Hardware not included.

Kawasaki	Part No.
750/800 Spacer	251-75010
750/800 Spacer Angled	251-80000
Reed Gasket	7050
6x50mm Stainless Steel Studs (Sold Each)	62-3050

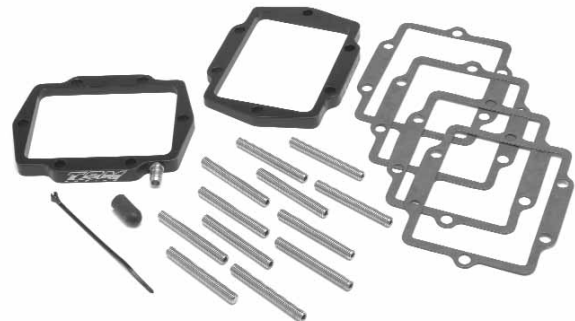

TBM ANGLED REED SPACER

TBM angled reed spacers position the reed cages in the optimal position for fuel atomization. Key features include a full 3 degrees of angle, an integrated pulse fitting, which allows you to add a second pulse line without drilling your crankcases. Compatible with stock, or aftermarket cages these spacers come complete with all necessary hardware and gaskets.

Kawasaki	Part No.
K750/800SX-R Angled Reed Spacer	TBM106



Sea Doo **Part No.**
 98GS/XL/XPL/GTXL **273-95000**
 *Excluded 97GS/XL
 950 Used with R&D Manifold 223-95000



REED VALVE STUFFERS

- Improves Airflow
- Quicker Throttle Response
- Easy Installation

R&D Reed Valve Stuffers significantly increase low-speed air velocity. This dramatically improves low/mid range throttle response and also top end performance. Exclusive internal wing design increases overall velocity through reed assembly.



Yamaha **Part No.**
 94-95 701 Raider / 760 **272-70301**
 Raider 96 701 Venture,
 96 Blaster / Blaster2
 96+ Super Jet OEM Manifold



Yamaha **Part No.**
 GP 1200R/GP1300R
 OEM Manifold **272-12000**



Kawasaki **Part No.**
 750/800SXR OEM Manifold **271-75001**
 750/800SXR R&D Manifold **271-75000**



RIVA/BOYSEN REED STUFFERS

Riva precision aluminum reed stuffers were designed to increase fuel/air velocity through the intake tract, resulting in increased throttle response and acceleration. These stuffers fit your stock reed cages and match perfectly with the original intake manifold. Will not warp or loose shape like traditional plastic stuffers. A very economical bolt-on performance modification.

Yamaha **Part No.**
 701 (62T) 2 pcs. **RY1402**

REPLACEMENT THROTTLE CABLES



Sea Doo	OEM#	Part No.
720 XP 95, 800 SPX 97-99,	277-000-468	002-039-03
800 SP 95-96		
580XP 91, 580GT 90-91	277-000-098	002-037
Yamaha		
500WR '87-'93, 650SJ '90-'93,	EUO-U7252-01	58-3501
650 WR/WRIII/LX/WR VXR '90-'96		
701 SJ '90-'95, WR701 '96-'97, W/B701 '93-'95,		
701WRII GP '94-'95,		
701 WR Pro VXR '93-'94, 701 WRII '97		
701 WR DX 95, 701 WV 95-96	GJ1-U7252-00	002-057
1100 WR 95-96, 1100 WV 96		
Kawasaki		
440 '77-'86, 550 '82-'86	54012-3001	58-3121

FUEL SYSTEMS
ENGINE/GASKETS
EXHAUST
DRIVE LINE HANDLING
ELECTRICAL
WATERLINE /BILGE
STEERING & CONTROLS
BODY
ACCESSORIES
SERVICE TOOLS /HARDWARE
CHEMICAL
FREESTYLE & 800SXR
FOUR STROKE



RACING FLAME ARRESTORS

(without Cotton Media)

Experience increased horsepower and engine protection with K&N Personal Watercraft flame arrestors for both normal and race applications. K&N "RACING ONLY" flame arrestors have an epoxied screen filter that does not have the cotton media.

K&N flame arrestors replace the restrictive factory airbox. In most cases an adapter is required (for adapters see pages 30 & 31) to mount the flame arrestor onto the carburetor. Some watercraft may require a slight adjustment to the carburetor's fuel circuits to allow for optimum performance.

4" Tall



Height	Top Color	Part No.
4"	Black Composite	59-2040RK
4"	Stainless Steel	59-2040R
Water Repellent Pre-Filter WR145-10-4DT		

2-1/2" Tall



Height	Top Color	Part No.
2-1/2"	Black Composite	59-2042RK
2-1/2"	Chrome	59-2042R
Water Repellent Pre-Filter WR145-115-25DT		

1-1/2" Tall



Height	Top Color	Part No.
1-1/2"	Chrome	59-2044R

2" Tall



Height	Top Color	Part No.
2"	Black Metal Top	59-2046
Water Repellent Pre-Filter WR125-2DT		



2006 WORLD FINALS • LAKE HAVASU, AZ
PHOTO COURTESY OF JIN OMURA

K&N REGULAR FLAME ARRESTORS

(with Cotton Media)

Regular K&N flame arrestors come with K&N's oiled cotton media sandwiched between screen material.

K&N flame arrestors replace the restrictive factory airbox. In most cases an adapter is required (for adapters see pages 30 & 31) to mount the flame arrestor onto the carburetor. Some watercraft may require a slight adjustment to the carburetor's fuel circuits to allow for optimum performance.



SINGLE 4-1/2" X 7" OVAL

Height	Part No.
3" Tall (45 degree)	59-2010
3" Tall (40 degree/Tapered)	59-2015
2" Mikuni Wet Suite	25-5911

DUAL 5-1/2" X 9" OVAL

Height	Center to Center	Part No.
2-1/2" Tall	4-1/16"	59-2840
2-1/2" Tall	3-13/16"	59-2910

HOT PRODUCTS RACING POWER FILTERS

by Tau Ceti



Tau Ceti's new Pro Series II Flame Arrestors are constructed from top quality materials such as aircraft grade aluminum, stainless steel, and a superior quality rubber base. This Flame Arrestor is designed with both duration and superior performance in mind. Using an extremely light anodized aluminum top in Silver, Black, Blue, Green and Red and a stainless steel mesh, this product is 100% corrosion resistant. With our free flowing, **stainless steel mesh**, we achieved an increase in acceleration and a much better throttle response. The universal rubber mount will fit any personal watercraft with a stock carburetor using the appropriate adapter (for adapters see pages 30 & 31). No re-jetting is necessary on stock boats.



Description	Part No.
Cone Filter 3" Silver	53-4275-SIL
Cone Filter 3" Black	53-4275-BLK
Cone Filter 3" Blue	53-4275-BLU
Cone Filter 3" Green	53-4275-GRN
Cone Filter 3" Red	53-4275-RED
Water Repellent Pre-Filter	WR125-10-35DT

Description	Part No.
Round Filter 2" Silver	53-4272-SIL
Round Filter 2" Black	53-4272-BLK
Round Filter 2" Blue	53-4272-BLU
Round Filter 2" Green	53-4272-GRN
Round Filter 2" Red	53-4272-RED
Water Repellent Pre-Filter	WR125-2DT

Description	Part No.
Round Filter 1.5" Silver	53-4270-SIL
Round Filter 1.5" Black	53-4270-BLK
Round Filter 1.5" Blue	53-4270-BLU
Round Filter 1.5" Green	53-4270-GRN
Round Filter 1.5" Red	53-4270-RED
Water Repellent Pre-Filter	WR125-15DT

*For information on Outwears Water Repellent Pre Filters please see page 31



MOTOINE RACING

MOTOINE FLAME ARRESTOR

Bottom I.D. 2-3/4" Height 2-3/8", Super Flow Flame Arrestor. Proven performance for years in Japan. This filter named "気", means "Air" and "Ancient natural Power by breathing", which only superhuman master can control. SAE.J 1928

Description	Part No.
Motoine Super Flow Flame Arrestor	MR-00009-01



K&N FILTERS AND ADAPTER FOR GO-PED®

Description	Part No.
A. K&N 3" x 2-1/2"	62-1480
B. K&N 3-1/2" x 1-1/2"	RC-2870
C. K&N 4-1/2" x 1-1/2"	RC-0340
D. Adapter for K&N	20-1001
E. K&N 3" x 2-1/2" W/chrome shield	62-1515

FUEL SYSTEMS	ENGINE/GASKETS	EXHAUST	DRIVE LINE HANDLING	ELECTRICAL	WATERLINE /BILGE	STEERING & CONTROLS	BODY	ACCESSORIES	SERVICE TOOLS /HARDWARE	CHEMICAL	FREESTYLE & 800SKR	FOUR STROKE
--------------	----------------	---------	---------------------	------------	------------------	---------------------	------	-------------	-------------------------	----------	--------------------	-------------

APPLICATIONS FOR K&N FILTERS & ADAPTERS

Model	Stock Carb Type & Quantity	Race K&N P#	Regular K&N P#	Adapter P#
SEA DOO				
580GTX 92-94	2/38M	59-2040RK	59-2910	53-4460
580GT 89-96	1/38M	59-2042RK	59-2010	53-4460
580GTS 93-96	1/38M	59-2042RK	59-2010	53-4460
580SP 88-96	1/38M	59-2042RK	59-2010	53-4460
580SPX 92-94	2/38M	59-2042RK	59-2910	53-4460
580 SPI 88-96	1/38M	59-2042RK	59-2010	53-4460
650XP 94	2/40M"1"	59-2042RK		53-4465
650XP 90-93	2/40M"1"	59-2042RK		53-4465
650GTX 95	2/40M"1"	59-2040RK		53-4465
650SPX 95	2/40M"1"	59-2042RK		53-4465
720XP 95	2/40M"1"	59-2042RK		53-4465
720GTI 97-99	1/40M"1"	59-2040RK		53-4465
720GTI 96	2/40M"1"	59-2040RK		53-4465
720GTS 97-00	1/40M"1"	59-2042RK	59-2010	53-4465
720SP 97	1/40M"1"	59-2042RK	59-2010	53-4465
720SPX 96	2/40M"1"	59-2042RK		53-4465
720HX95-97	2/40M"1"	59-2040RK	59-2010	53-4465
720GS 97-00	1/40M"1"	59-2040RK	59-2010	53-4465
720GSI 97	1/40M"1"	59-2040RK		53-4465
800GTX 96-97	2/40M"1"	59-2040RK		53-4465
800GSX 96-97	2/40M"1"	59-2040RK		53-4465
800XP 95-97	2/40M"1"	59-2042RK		53-4465
800SPX 97-99	2/40M"1"	59-2042RK		53-4465
950GSX LTD 97-99	2/46M"1"	59-2042RK		not required
950XP LTD 98-00	2/46M"1"	59-2042RK		not required
950GTX LTD 98-99	2/46M"1"	59-2042RK		not required
YAMAHA				
W/Jammer 500 88-89	1/38M	59-2042RK	59-2000	53-4460
W/Runner 500 88-89	1/38M	59-2042RK	59-2000	53-4460
W/runner 650 90-95	1/44M	59-2042RK	59-2000	53-4480
W/Runner III 650 90-95	1/44M		59-2020	
VXR 650 91-95	1/44M		59-2020	
Super Jet 650 90-93	1/44M	59-2042RK	59-2000	53-4480
W/Raider 701 94-95	2/38M	59-2040RK		53-4462
W/Raider 70196-97	1/44M	59-2040RK		53-4482
W/Venture 701 95-98	2/38M	59-2040RK		53-4462
W/Blaster 701 96-97	2/38M	59-2042RK		53-4462
W/blaster 701 93-95	1/44M		59-2020	85-9491
Super Jet 701 94-95	1/44M	59-2042RK	59-2000	53-4480
Super Jet 701 96-00	2/38M	59-2042RK		53-4460
FX1 701 94-95	1/44M	59-2042RK	59-2000	53-4480
XL700 95-00	2/38M	59-2042RK		53-4462
GP760 97-00	2/44M	59-2040RK		53-4480
XL760 98-99	2/44M	59-2040RK		53-4482
W/Raider 760 96	2/44M	59-2040RK		53-4482
W/blaster II 760 96-97	2/44M	59-2040RK		53-4480
W/Venture 760 96-98	2/44M	59-2040RK		53-4480
GP800 98-00	2/44M NEW	59-2044R		53-4466
W/Raider 1100 95-06	3/38M	59-2040RK		53-4462
W/Venture 1100 96-98	3/38M	59-2040RK		53-4462
XL1200 98	3/44M	59-2040RK		53-4480
GP1200 97-99	3/44M	59-2040RK		53-4480
GP1200R 00	3/44M NEW	59-2044R		53-4466
KAWASAKI				
JS300 86-91	1/38M	59-2042RK	59-2000	53-4460
JS400 74-76	1/38M	59-2042RK	59-2000	53-4460
JS440 77-90	1/38M	59-2042RK	59-2000	53-4460
JS440 91-92	1/42K	59-2042RK	59-2000	53-4440
JS550 82-85	1/38M	59-2042RK	59-2000	53-4460
JS550 86-90	1/44M	59-2042RK	59-2000	53-4480

Model	Stock Carb Type & Quantity	Race K&N P#	Regular K&N P#	Adapter P#
KAWASAKI				
JS550SX 91-95	1/42K	59-2042RK	59-2000	53-4440
650X2 89-94	1/28K	59-2042RK	59-2015	
JS650SX 89-94	1/28K	59-2042RK	59-2000	
650TS 89-96	1/38K	59-2042RK		53-4440
650SC 90-95	1/38K	59-2042RK	59-2000	53-4440
750SX 92-95	1/40K	59-2042RK	59-2860	53-4440
750SXI 95	1/38K	59-2042RK		53-4450
750SXI 96-97	2/40M"1"	59-2042RK		53-4465
750SXI PRO 98-00	2/40M"1"	59-2042RK		53-4465
750SS 92-98	1/40K	59-2042RK	59-2860	53-4440
750XI 93-97	2/40K	59-2042RK		53-4440
750XIR 94	2/40K	59-2042RK		53-4440
750ST 94-95	1/40K	59-2042RK	59-2860	53-4440
750STS 95-97	2/38K	59-2042RK		53-4450
750ZXI 95-98	2/38K	59-2042RK		53-4450
900ZXI 95-97	3/38K	59-2040RK		53-4450
900STX 97-99	3/38K	59-2040RK		53-4450
1100ZXI 96-97	3/38K	59-2040RK		53-4450
1100STX 97-99	3/38K CDCV	59-2040RK		AD-K38-12
ULTRA150 99-00	3/40K CDCV	59-2040RK		K40-TA02
POLARIS				
SL650 92-95	3/38M	59-2042RK		53-4460
HURRICANE700 96-97	2/38K	59-2042RK		53-4440
SL/SLT700 96-97	2/38K	59-2042RK		53-4440
SLH700 98-00	2/38K	59-2042RK		53-4440
SL/SLT750 93-95	3/38M	59-2042RK		53-4460
SL/SLT780 96-97	3/38M	59-2042RK		53-4460
SLX780 95-96	3/38M	59-2042RK		53-4460
SLXPRO785 97-00	3/44M	59-2042RK		53-4480
SL900 96-97	3/38K	59-2042RK		53-4440
SL/SLTX1050 96-00	3/38K	59-2042RK		53-4440
SLXH1050 98-99	3/38K	59-2042RK		53-4440
Genesis 99-00	3/38K	59-2042RK		53-4440
1200 PRO 00	3/38K	59-2042RK		53-4440
Virage/TX 00	3/38K	59-2042RK		53-4440
TIGER SHARK				
Daytona650 92-93	1/46M	59-2042RK		53-4490
Daytona650 95	2/38M	59-2042RK		53-4460
MonteCarlo650 94-95	1/46M	59-2042RK		53-4490
MonteCarlo650 96	1/44M	59-2042RK		53-4480
MonteCarlo650 97	1/40M"1"	59-2042RK		53-4465
Montego650 94-96	1/44M	59-2042RK		53-4480
Montego650 97	1/40M"1"	59-2042RK		53-4465
Barracuda650 93-95	1/46M	59-2042RK		53-4490
Daytona770 96-97	2/40M"1"	59-2042RK		53-4465
MonteCarlo770 96-97	2/40M"1"	59-2042RK		53-4465
MonteCarlo900 95	3/44M	59-2042RK		53-4480
MonteCarlo900 96	3/40M"1"	59-2042RK		53-4465
Daytona1000 97-98	3/40M"1"	59-2042RK		53-4465
MonteCarlo1000 97-98	3/40M"1"	59-2042RK		53-4465
TS640 98-99	1/38M	59-2042RK		53-4460
TS770 98-99	1/38M	59-2042RK		53-4460
TS770R 98-99	2/38M	59-2042RK		53-4460
TS770L 98	2/38M	59-2042RK		53-4460
TS770L 99	1/38M	59-2042RK		53-4460
TS1000 98	3/40M"1"	59-2042RK		53-4465
TS1000L 98	3/40M"1"	59-2042RK		53-4465
TS1100R	3/40M"1"	59-2042RK		53-4465

ALUMINUM AIR FILTER ADAPTERS FOR KEIHIN CARBURETORS, SOLD EACH



Keihin Part No.
38/40/42mm (50mm Bore) 53-4440



Keihin Part No.
OEM Carb (44mm Bore) 53-4450
K750 SXI-95,750ZXI, K900/1100ZXI



Keihin CDCV Part No.
Ultra 150/STX-R AD-K40-14
ZXI/STX 98-02 AD-K38-12

ALUMINUM AIR FILTER ADAPTERS FOR MIKUNI CARBURETORS. SOLD EACH.



Mikuni	Part No.
38mm 38mm Bore	53-4460
44mm 46mm Bore	53-4480
46mm 48mm Bore	53-4490



Mikuni	Part No.
38mm w/oil injection only	53-4462
44mm w/oil injection only	53-4482



Mikuni	Part No.
OEM 40mm "I" Series (48mm Bore)	53-4465
Sea Doo HX/XP, K750 SXI 96-02, K800SXR 03-06	



Mikuni	Part No.
OEM Carb Yamaha GPR Series (57mm Bore)	53-4466



OIL INJECTION SPACER PLATES

Description	Part No.
Mikuni 44mm	53-4485
Mikuni 46mm	53-4495
Press in Nipple (1/8") only	53-9936



MIKUNI WETSUIT FOR K&N 2" OVAL FILTERS



Silicone treated foam filter wrap designed to repel water without restricting the air flow to the engine. This cover is a great solution for keeping your filter dry while your riding.

Description	Part No.
Mikuni Wetsuit Color is Blue	25-5911

Outerwears Racing Accessories

The Outerwears Pre-filter is an excellent solution to prevent water from entering into the engine without restricting air flow or causing a loss in performance. An Outerwears Pre-Filter is designed to be water repellent and will reduce the risk of water entering through an air intake system. Outerwears offers water repellent pre-filters for K&N, Tau Ceti, ProK and R&D performance air filters and flame arrestors.

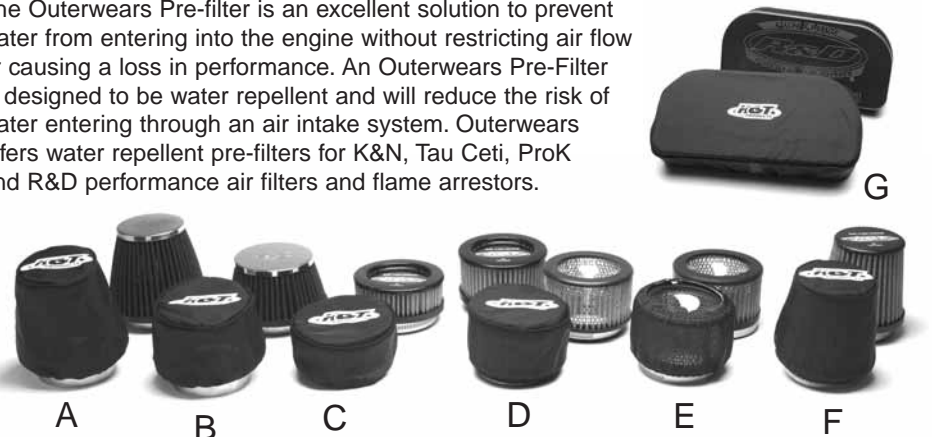

Description	Flame Arrestor Type	Part No.
A. 4.25" x 3" Taper/4" Tall	K&N 59-2040R/RK	WR145-10-4DT
B. 4.25" x 3.5" Taper/2.5" Tall	K&N 59-2042R/RK	WR145-115-25DT
C. 4" dia/1.75" Tall	Tau Ceti 53-4270	WR125-15DT
D. 4" dia/2.25" Tall	Tau Ceti 53-4272. ProK	WR125-2DT
E. 4" dia/2.25" Tall (Open Top)	Tau Ceti 53-4272, ProK	WR125-225
F. 4" x 3" Taper/3.5" Tall	Tau Ceti 53-4275	WR125-10-35DT
G. Pro-Lock SD951/2.5" Tall	R&D 203-95000	WR30-25DTPRO

*For information on air filters and flame arrestors please see pages 28-30 & 32-33

FUEL SYSTEMS
ENGINE/GASKETS
EXHAUST
DRIVE LINE HANDLING
ELECTRICAL
WATERLINE /BILGE
STEERING & CONTROLS
BODY
ACCESSORIES
SERVICE TOOLS
CHEMICAL
HARDWARE
FREE STYLE & 800SXR
FOUR STROKE



R&D PRO-LOCK POWER PLENUM

FOR TWO STROKE MOTOR



Kawasaki	Part No.
1200STXR Stock Carb/Stock Pipe	200-01240
1200STXR With Triple Pipe	200-02240

Kawasaki	Part No.
800SXR Stock Carb (I Series Adapters Included)	200-00800
800SXR Aftermarket Carb	200-00120
120mm center to center (Adapter not included)	



Sea Doo	Part No.
951 All	203-95000

Yamaha	Part No.
GP1300R Stock Fuel Injection	200-13143
GP1200R/XLL/XLT1200	200-00142

Kawasaki	Part No.
Ultra 150 1200cc Stock Carbs	200-00140

FOR FOUR STROKE MOTOR



R&D GTX 4-TEC SUPERCHARGER FILTER KIT

The R&D GTX 4-TEC high performance "supercharger" air intake/filter kit will eliminate power robbing air intake restriction caused by a long intake tube design and promote a noticeable bolt of low and mid range acceleration and boost top end performance 1 - 1.5 mph! Rev up additional 100 plus RPM's. The filter kit installs very easily in 10-20 minutes, and has provisions in the filter to install the OEM crankcase ventilator!

R&D POWER PLENUM FILTER KIT

The new R&D RXP Power Plenum Air Filter Kit will get the job done with definite noticeable increase in throttle response and acceleration, as well as increase RPM's between 50 - 100! R&D Power Plenum Filter Kits have been dyno tested and race proven to add 3 to 5 horsepower on stock four stroke 1500cc engines! The R&D RXP Power Plenum Filter Kit gives the RXP 215's engine a high performance racing look, sound, and performance without sacrificing an ounce of reliability!

Sea Doo	Part No.
GTX Supercharged, RXT (For 185 & 215 HP Engine)	203-95003
GTX 4-Tec N.A. (155 HP Engine)	203-95002

Sea Doo	Part No.
Sea Doo RXP (215 HP Engine)	203-00215



R&D POWER PLENUM HIGH PERFORMANCE FLAME ARRESTOR KIT

The new R&D F12 / F 15 Power Plenum Air Filter kit delivers a noticeable increase in throttle response and acceleration, as well as increase RPM's between 50 and 100.

Kawasaki	Part No.
STX-F12/F-15	215-15010



R&D REPLACEMENT PERFORMANCE FILTER

The new R&D Replacement Performance Filter replaces the stock restrictive perforated filter plate and allows for improved airflow. Amounts directly into the stock filter box and retains the OEM look. The improved airflow increases throttle response, RPM, and top speed.

Kawasaki	Part No.
STX-F12/F15	215-15000



R&D POWER PLENUM FILTER

The new R&D Honda R-12X Power Plenum Filter delivers a noticeable increase in throttle response and acceleration, as well as increase RPM's between 50 and 100.

Honda	Part No.
R-12X	200-51200



R&D POWER PLENUM FLAME ARRESTER

The R&D High Flow Power Plenum replaces the restrictive stock flame arrester allowing more improved airflow, why? Because more air flow with less restriction means more power!

Yamaha	Part No.
FX 140/Cruiser	200-00144
FX HO/Cruiser	



R&D HIGH FLOW POWER PLENUM AIR BREATHER

The R&D High flow breather is a direct replacement for the stock breather in the OEM air box. Water tested to deliver improved throttle response, acceleration and top speed with 50-100 RPM increase.

Yamaha	Part No.
FX 140/Cruiser	200-00143
FX HO/Cruiser	



VELOCITY STACK KIT

The R&D Velocity Stack Kit is a direct bolt-on kit that replaces the restrictive OEM stacks. Designed to increase air velocity into the throttle bodies producing improved throttle response and top end speed. Easily installs with OEM hardware.

Yamaha	Part No.
FX 140/Cruiser	206-00140
FX HO/Cruiser	



VX PERFORMANCE AIR FILTER KIT

The new R&D Performance Air Filter for the VX 110 is now available. The R&D High Flow Filter design replaces the restrictive stock filter inside the stock air box, allowing improved air flow. Why? Because more air flow means more power and improved performance.

Yamaha	Part No.
VX 1100 for Stock Carb Air Box	200-00110



GP 1300R POWER STACK AIR FILTER KIT

The R&D GP 1300R Power Stack Air Filter Kit is designed to assemble on to the front of the OEM air plenum box. The R&D Power stack adds bottom and mid range power performance while increasing engine RPM's.

Yamaha	Part No.
GP 1300R for Stock Box	200-13100

FUEL SYSTEMS	ENGINE/GASKETS	EXHAUST	DRIVE LINE HANDLING	ELECTRICAL	WATERLINE /BILGE	STEERING & CONTROLS	BODY	ACCESSORIES	SERVICE TOOLS /HARDWARE	CHEMICAL	FREESTYLE & 800SKR	FOUR STROKE
--------------	----------------	---------	---------------------	------------	------------------	---------------------	------	-------------	-------------------------	----------	--------------------	-------------



RIVA RXP/RXT/GTX-SC POWER FILTER KIT

Delivers greatly improved acceleration and a 1~2 mph (150~200 rpm) top speed increase by replacing the restrictive stock intake system. The Power Filter® feeds your supercharger with a steady diet of cool air via a large 3" diameter intake duct and oversized K&N filter element. Ducting is precision formed from a race proven composite that will not conduct heat to incoming air. Installs securely via a silicone coupler and sturdy bracket. Includes pre-filter element.

NOTE: It will be necessary to upgrade your stock pump impeller to a steeper pitch when using our Power Filter Kit. Sea Doo and RIVA both strongly recommend the use of premium octane (91+) pump fuel in your Supercharged watercraft.

Sea Doo	Part No.
Power Filter Kit, Performance, SD RXP/RXT (04-07) GTX-SC	RS13050-06
Power Filter Kit, Performance, SD (03) GTX-SC only	RS13050-03
Power filter only, for RS 13050-03/06	RS13050-2

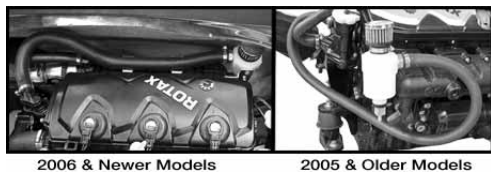

RIVA RXP/RXT CATCH CAN/OIL BREATHER SYSTEM

Easy to install catch can/oil breather eliminates power-robbing crankcase fumes and oil vapor from your engine's air intake. Increases horsepower by removing the engine's requirement to burn relatively non-combustible oil. Also improves intercooler efficiency by preventing the oil sludge coating that lowers thermal efficiency. Excess oil vapor is routed to our translucent catch can where it condenses and collects for occasional draining via integrated petcock valve. Kit included K&N breather and Sea-Doo mounting bracket along with all necessary hardware & installation instructions.

Sea Doo	Part No.
Breather, Catch Can Kit, SD RXP RXT GTX 4-TEC	RS19050-BCC



VX110 POWER FILTER KIT

Screen-type filter element replaces restrictive stock air filter. Extended intake tube draws cooler air into engine significantly improving performance. Includes pre-filter.

Yamaha	Part No.
VX110	RY13030

RIVA RXP PRO-SERIES POWER FILTER KIT

Our RXP Pro-Series Power Filter is a race-bred air intake system that draws cool air from outside your engine compartment delivering incredible performance and eliminating power-robbing heat intake. Air enters the system under seat through a billet aluminum intake flange equipped with a water-repellent pre-filter. Precision formed ducting attaches to supercharger via a large 4" adapter. Kit includes a complete oil catch can/breather system that keeps hot oil vapor and crankcase fumes from entering your engine's air intake. Also contains two Flow-Rite® water-repellent vents for improved ventilation of engine compartment through engine cowling. **NOTE:** This product is not designed for heavy surf use due to possibility of water ingestion. We recommend RIVA Power Filter part#RS13050-YEAR for this application.

Sea Doo	Part No.
Power Filter Kit, Pro-Series, SD RXP	RS13056
Pre-Filter Assembly only, For RS13056	RS13056-PF

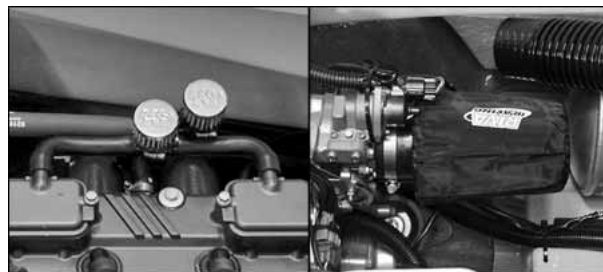

RIVA ULTRA LX/STX-F PERFORMANCE POWER FILTER KIT

- Increases airflow and power.
- Installs easily.
- Mounts directly onto stock throttle body.
- Built to our specifications by K&N.
- Includes two smaller K&N filters for engine breather hoses and water repellent pre-filter cover for primary filter.

Kawasaki	Part No.
Power Filter, Performance, KAW Ultra LX/STX-F	RK13085



RIVA POWER FILTER FOR GP1300R

Power filter fits directly onto OEM air box assembly. Kit comes with water repellent filter.

Yamaha	Part No.
Flame Arrestor, Power Filter Kit GP1300R (60T)	RY1312