

# RIVA PERFORMANCE PARTS KIT AND RPM KITS



## RXP STAGE I KIT

Kit Part # RS-RPM-RXP-1  
Stock 67-68 mph  
RPM Kit 72 mph @ 8,100 RPM

Description	Quantity	Part No.
RIVA RXP Power Filter Kit	1	RS13050-06
RIVA RXP Pump Wedge	1	RS23050
RIVA RXP Top Loader Intake Grate	1	RS22050
Solas Concord Impeller	1	SRX-CD-14/19R

## RXP STAGE II KIT

Kit Part # RS-RPM-RXP-2  
Stock 67-68 mph  
RPM Kit 75 mph @ 8,100 RPM

Description	Quantity	Part No.
RIVA RXP Power Filter Kit	1	RS13050-06
RIVA RXP Supercharger Impeller	1	RS1750-001A
RIVA RXP Power Cooler Kit	1	RS1750-PC
RIVA RXP Rear Exhaust Kit	1	RS15050-1
RIVA RXP Top Loader Intake Grate	1	RS22050
Solas Concord Impeller	1	SRX-CD-15/20R
RIVA RXP Pump Wedge (2-degree)	1	RS23050
RIVA RXP Pro-Series Sponson Kit	1	RS26050
RIVA O.P.A.S. Performance Block-off Kit	1	RS29050-1

## RXP STAGE III KIT

Kit Part # RS-RPM-RXP-3  
Stock 67-68 mph  
RPM Kit 80+ mph @ 8,400 RPM

Description	Quantity	Part No.
RIVA RXP Power Filter Kit	1	RS13050-06
RIVA RXP Pro-Series Supercharger Housing & Impeller	1	RS1750-2M011
RIVA RXP Power Cooler Kit with Pro-Series Blow-off Valve	1	RS1750-PC-001
RIVA RXP Pro-Series Fuel Injector Kit	1	RS12050-I-KIT
RIVA RXP Rear Exhaust Kit	1	RS15050-1
RIVA Pro-Series ECU*	1	RS11850-01-YEAR*
*2004-05 = A • 2006 = B • 2007 = C		
RIVA RXP Thermostat Kit	1	RS1015
RIVA RXP Valve Spring Retainer Kit	1	RS19050-VTU
RIVA RXP Heavy Duty Supercharger Clutch Washers	1	RS1750-HDW-946
RIVA RXP Top Loader Intake Grate	1	RS22050
RIVA/Skat-Trak Swirl Impeller with Billet Nose Cone	1	SP-IMP-159-15-19R
RIVA RXP Pump Wedge (2-degree)	1	RS23050
RIVA RXP VTS Extension Rod	1	RS23050-ER
RIVA RXP Pro-Series Reduction Nozzle	1	RS23050-N
RIVA RXP Pro-Series Sponson Kit	1	RS26050
RIVA O.P.A.S. Performance Block-off Kit	1	RS29950

## RXT STAGE I KIT - RXT/05-06 GTX SC-LTD

Kit Part # RS-RPM-RXT-1  
Stock 64-65 mph  
RPM Kit 68-69 mph @ 8,100 RPM

Description	Quantity	Part No.
RIVA RXT Power Filter Kit	1	RS13050-06
RIVA RXT Pump Wedge	1	RS23050
RIVA RXT Top Loader Intake Grate	1	RS22055
Solas Concord Impeller	1	SRX-CD-14/17R
RIVA O.P.A.S. Competition Kit	1	RS29055

## RXT STAGE II KIT - RXT/05-06 GTX SC-LTD

Kit Part # RS-RPM-RXT-2  
Stock 64-65 mph  
RPM Kit 71-72 mph @ 8,100 RPM

Description	Quantity	Part No.
RIVA RXT Power Filter Kit	1	RS13050-06
RIVA RXT Supercharger Impeller	1	RS1750-001A
RIVA RXT Power Cooler Kit	1	RS1750-PC
RIVA RXT Rear Exhaust Kit	1	RS15050-1
RIVA RXT Top Loader Intake Grate	1	RS22055
Solas Concord Impeller	1	SRX-CD-13/19R
RIVA RXT Pump Wedge (2-degree)	1	RS23050
RIVA RXT Pro-Series Sponson Kit	1	RS26050
RIVA O.P.A.S. Performance Block-off Kit	1	RS29050-1

## RXT STAGE III KIT - RXT/05-06 GTX SC-LTD

Kit Part # RS-RPM-RXT-3  
Stock 64-65 mph  
RPM Kit 74-75 mph @ 8,400 RPM

Description	Quantity	Part No.
RIVA RXT Power Filter Kit	1	RS13050-06
RIVA RXT Pro-Series Supercharger Housing & Impeller	1	RS1750-2M011
RIVA RXT Power Cooler Kit with Pro-Series Blow-off Valve	1	RS1750-PC-001
RIVA RXT Pro-Series Fuel Injector Kit	1	RS12050-I-KIT
RIVA RXT Rear Exhaust Kit	1	RS15050-1
RIVA Pro-Series ECU*	1	RS11850-01-YEAR*
*2004-05 = A • 2006 = B • 2007 = C		
RIVA RXT Thermostat Kit	1	RS1015
RIVA RXT Valve Spring Retainer Kit	1	RS19050-VTU
RIVA RXT Heavy Duty Supercharger Clutch Washers	1	RS1750-HDW-946
RIVA RXT Top Loader Intake Grate	1	RS22050
RIVA/Skat-Trak Swirl Impeller with Billet Nose Cone	1	SP-IMP-159-15-18R
RIVA RXT Pro-Series Reduction Nozzle	1	RS23051-N
RIVA RXT Pro-Series Sponson Kit	1	RS26050
RIVA O.P.A.S. Performance Block-off Kit	1	RS29950-1

\*When ordering the Riva Pro-Series ECU you must specify the year of the Sea Doo RXP or RXT.

FUEL SYSTEMS  
ENGINE/GASKETS  
EXHAUST  
DRIVE LINE HANDLING  
ELECTRICAL  
WATERLINE/BILGE  
STEERING & CONTROLS  
BODY  
ACCESSORIES  
SERVICE TOOLS/HARDWARE  
CHEMICAL  
FREESTYLE & BOOSXR  
FOUR STROKE

# RIVA PERFORMANCE PARTS KIT AND RPM KITS

## YAMAHA FX 140 & FX CRUISER RPM KIT

Kit Part # RY-RPM-FX140  
 Stock 54-55 mph @10,100 RPM  
 RPM Kit 59 mph @10,300 RPM

Description	Quantity	Part No.
RIVA FX Power Filter Flame Arrestor	1	RY1325
RIVA FX Velocity Stack Kit	1	RY 1325-VSK
RIVA FX Free Flow Exhaust Kit	1	RY1625
RIVA FX Top loader Intake Grate	1	RY22325
RIVA FX Pump Seal kit	1	RY2525
RIVA/Solas Set Back Concord Impeller	1	YF-CD-12/19-SB
RIVA FX 140 Performance Ride Plate 05-06 Models (02-04 models order Part # RY21025)	1	RY21026
RIVA FX Pro Series Sponson Kit	1	RY2625

## YAMAHA FX-HO & FX-HO CRUISER RPM KIT

Kit Part # RY-RPM-FXHO  
 Stock 59-60 mph @10,100 RPM  
 RPM Kit 64 mph @10,300 RPM

Description	Quantity	Part No.
RIVA FX Power Filter Flame Arrestor	1	RY1325
RIVA FX Velocity Stack Kit	1	RY 1325-VSK
RIVA FX Free Flow Exhaust Kit	1	RY1625
RIVA FX Top Loader Intake Grate	1	RY22325
RIVA FX Pump Seal kit	1	RY2525
Solas DynaFly Impeller	1	YG-DF-14/20
RIVA FX-HO Performance Ride Plate	1	RY21026
RIVA FX Pro Series Sponson Kit	1	RY2625

## KAWASAKI STX-15F RPM KIT

Kit Part # RK-RPM-15FOS  
 Stock 61 mph @7,500 RPM  
 RPM Kit 66 mph @7,650 RPM

Description	Quantity	Part No.
RIVA STX-F Power Filter Flame Arrestor	1	RK13085
RIVA FX Top loader Intake Grate	1	RK16085
Solas Concord Impeller	1	KG-CD-14/21
R&D STX-F Performance Ride Plate	1	121-12000
R&D STX-F Ride Plate	1	121-15011
Reverse Gate Brackets		
RIVA STX-F Pro Series Sponson Kit	1	RK26085



### PERFORMANCE DATA

Stock  
 61 MPH @ 7,600 RPM  
 Supercharged  
 80+ MPH @ 8,300 RPM

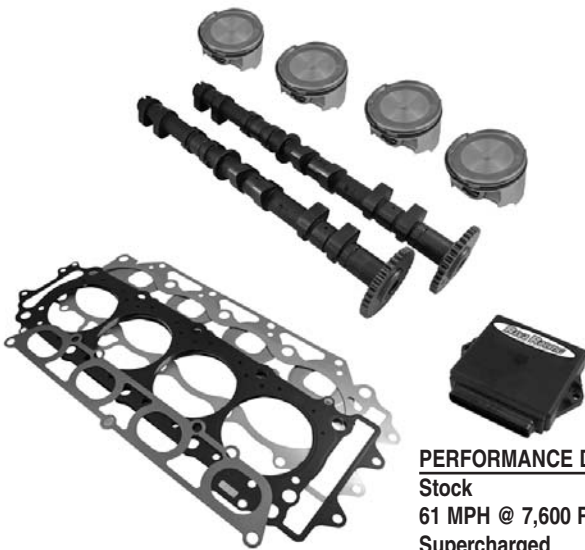

**PERFORMANCE DATA**  
 Stock  
 61 MPH @ 7,600 RPM  
 Supercharged  
 71 MPH @ 8,100

## RIVA STX-15F OFFSHORE RACE KIT

Our Offshore Racing Kit for the Kawasaki STX-15F contains the same components and specifications that Team Kawasaki developed to dominate the international racing circuit. This modification delivers over 200hp producing awesome acceleration and a top speed of over 700mph using VP MS109 race fuel (Jet X). Kit includes high compression racing pistons, performance intake & exhaust cam shafts, Race programmed ECU along with all necessary gaskets and detailed installation instructions.

Kawasaki	Part No.
STX-15F Offshore Kit 04-06	RK1000-15F
STX-15F Offshore Kit 07	RK1000-15F-07



Riva/Vortech Supercharged STX-15F Engine  
 (Team Kawasaki Spec)

## RIVA / VORTECH STX-15F SUPERCHARGER KIT

Our race bred Supercharger System for the Kawasaki STX-15F contains all necessary engine components to produce the ultimate 80mph closed course race craft. Kit contains the same specifications that Team Kawasaki won two 2004 Pro Runabout World Titles with. System produces over 300hp using VP MS109 race fuel (Jet X). Kit includes Vortech Supercharger & Intercooler Forged Racing Pistons, Free flow Exhaust Kit, Race programmed ECU, High volume Injectors & Fuel Pump along with all necessary hardware and detailed installation instructions.

Kawasaki	Part No.
STX-15F Supercharger Kit	RK1785
STX-15F Pro Service Power Filter Kit for Super Charger	RK13086



Power Cooler Kit with Performance Blow-off Valve



Power Cooler Kit with Pro-Series Blow-off Valve

Block off for OE Intercooler

Power Cooler Mounting Bracket



RS1750-PC-TK



RS1750-PC-UK

## RIVA SD POWER COOLER

The RIVA Power Cooler is a significantly improved intercooler system for the Sea Doo 215hp Intercooled Supercharged 4-TEC engine. Delivers an increase of 15-peak horsepower over original intercooler providing arm-wrenching results on the water. Realizing that boost loss was just as important as thermal performance, we designed the Power Cooler with a large, unrestricted core that exhibits minimal pressure loss. Our cooling element is dramatically more efficient than the stock unit with exit temperatures averaging 50°F cooler than stock. This delivers cooler, denser air for increased performance throughout the RPM range. Includes integrated blow-off valve that improves supercharger reliability and performance by relieving unwanted pressure during off-throttle operation. Also reduces supercharger clutch wear and eliminates heat soak in discharge tube. Kits contain all necessary mounting hardware and installation instructions. Requires use of RIVA Rear Exhaust Kit (Part #RS15050) see page 69.

Description	Part No.
Power Cooler, w/Performance Blow-off Valve SD RXP/RXT/05-06 GTX-SC Ltd.	RS1750-PC
Power Cooler, w/Pro-Series Blow-off Valve SD RXP/RXT/05-07 GTX-SC Ltd.	RS1750-PC-001
Upgrade kit, Pro-Series Aluminum Tube Set (for RS1750-PC) Includes Performance Blow-off Valve	RS1750-PC-UK
Upgrade Kit, Pro-Series Aluminum Tube Set (for RS1750-PC)	RS1750-PC-TK
Exhaust Kit, Rear, SD RXP/RXT/04-07 GTX-SC	RS15050-1

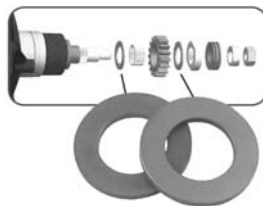

## HEAVY-DUTY SD SUPERCHARGER CLUTCH WASHERS

These are direct replacements for the original ceramic clutch washers that are prone to fail on modified engines. Precision machined from tool grade steel and then coated with a special Titanium process to increase durability. Will not break up and damage engine at end of service life.

Riva	Part No.
Washers, Heavy-duty Clutch '04-05 RXP/RXT/GTX Supercharger	RS1750-HDW-945
Washers, Heavy-duty Clutch '06 RXP/RXT/GTX Supercharger	RS1750-HDW-946

R&D	Part No.
Sea Doo RXP 215 h.p. / RXT and GTX SC	613-95001
Sea Doo 185 h.p.	613-95002



## RIVA PRO-SERIES SD SUPERCHARGER HOUSING AND IMPELLER

Our high performance impeller & housing combo deliver a significant increase in boost pressure and horsepower due through increased impeller blade surface area and larger interior housing volume. Produces 10.5lbs of boost at 8,400 RPM when run with our recommended Stage III components. Impeller features a sophisticated Vortech blade design that is precision balanced to deliver smooth operation. Housing and impeller install easily onto stock supercharger base plate with no additional modifications required. Includes all necessary mounting hardware and installation instructions.

Description	Part No.
Supercharger Housing & Impeller SD RXP/RXT/05-07 GTX-SC Ltd.	RS1750-2M011



## RIVA/VORTECH RXP/RXT/GTX-SC SUPERCHARGER IMPELLER

The heart of any centrifugal supercharger is the impeller. Working closely with Vortech Engineers, we developed a high performance replacement impeller that delivers more horsepower and torque throughout the RPM range. Investment cast from an extremely strong, lightweight proprietary aluminum and CNC machined to ensure exact tolerances. Sophisticated blade design is optimized aerodynamically and precision balanced to deliver smooth operation. Installs easily into stock supercharger housing with no additional modifications required. Includes all necessary mounting hardware and installation instructions.

NOTE: It will be necessary to upgrade your stock pump impeller to a steeper pitch when using our Supercharger Impeller. Sea Doo and RIVA both strongly recommend the use of premium octane (91+) pump fuel in your Supercharged watercraft.

Description	Part No.
Supercharger Impeller, all SD RXP/RXT/GTX-SC	RS1750-001A
Nut, Supercharger Impeller, RIVA	RS1750-001A-N

FUEL SYSTEMS  
ENGINE/GASKETS  
EXHAUST  
DRIVE LINE HANDLING  
ELECTRICAL  
WATERLINE /BILGE  
STEERING & CONTROLS  
BODY  
ACCESSORIES  
/HARDWARE  
CHEMICAL  
FREESTYLE & BOOSXR  
FOUR STROKE



### RIVA SD SUPERCHARGER BLOW-OFF VALVE KIT

Our Blow-off Valve Kit improves supercharger reliability and performance by relieving unwanted pressure during off-throttle operation. Reduces supercharger clutch wear and eliminates heat soak in discharge tube. High-strength silicone hose with integrated blow-off valve installs easily in place of OEM elbow joint. Includes K&N filter to prevent debris from entering valve outlet. A simple and cost effective upgrade for both stock and modified supercharged engines. Includes all necessary mounting hardware and installation instructions.

Sea Doo	Part No.
Blow-off Valve Kit, SD Supercharger, RXP/RXT/GTX-S	RS1750-BV

**NEW**



### RIVA SEA DOO VALVE TRAIN UPGRADE KIT

Our Valve Train Upgrade Kit increases the reliability of your modified engine by reducing the possibility of valve float at high rpm. Includes lightweight, precision-machined titanium valve retainers, racing valve springs, base washers and OE rocker arm shaft bolts that must be replaced during installation.

Sea Doo	Part No.
Upgrade Kit, Valve Train, SD RXP/RXT/GTX	RS19050-VTU
Tool, Valve Compression, SD 4-TEC	RS19050-VCT

**NEW**



### RIVA RXP/RXT/GTX THERMOSTAT KIT

Our cool running Thermostat Kit reduces the operating temperature of your modified 4-Tec® engine by 30°F for maximum reliability and performance. Kit includes replacement thermostat, billet coolant inlet flange, stock thermostat removal tool, Oetiker® clamps, Oetiker® pliers and detailed installation instructions. NOTE: Thermostat housing (shown above) not included.

Sea Doo	Part No.
Thermostat Kit, SD RXP/RXT/GTX	RS1015



### R&D SEA DOO RXP CRANKCASE BREATHER KIT

The R&D Crankcase Breather Kit will add a high performance look to the RXP's engine compartment! The R&D Crankcase Breather Kit eliminates power-robbing crankcase fumes from the engines main air intake. Cleaner mass air equals more power!

Sea Doo	Part No.
Sea Doo RXP Crankcase Breather Kit	203-00216

**NEW**



Temperature ranges of 107-217 & 138-248 degrees F  
 Accurate within 1-2 degrees  
 Reversible thermometer with long lasting adhesive  
 Aids in maintenance and diagnosis  
 Know it before you blow it



### RACETEMP® SAVING MOTORS EVERYWHERE!

Detect overheating and monitor engine components with the Racetemps® temperature monitoring device. Racetemps® is a small visible strip that enables machine operators to quickly and accurately determine the temperature of vital components such as: radiator, cylinder, rear shock body, clutch housings and more. This product aids in vehicle maintenance, monitoring and troubleshooting.

Description	Part No.
Race Engine Thermometer Pack of three + decal	RT138-248

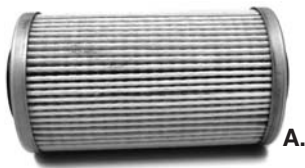

**NEW**

## OEM REPLACEMENT AFTERMARKET OIL FILTERS

Sea Doo	Part No.
A. All Sea Doo 4-stroke	006-560
B. All Sea Doo 4-stroke oil filter cap	006-562

Yamaha	Part No.
Yamaha FX/VX 594-13440-00-00	006-563



## SUPERCHARGER SLEEVE FOR SEA DOO RXP / RXT / GTX SC

The sleeving up of the diameter of the Supercharger enables a 3.5" or 4" intake/filter system to be utilized. The larger intake increases cubic air volume as well as decreases air inlet restriction. A win/win, Supercharge your supercharger and give it more air!

Sea Doo	Part No.
Supercharger Sleeve 3.5" diameter	613-95035
Supercharger Sleeve 4" diameter	613-95040



## HYDRO-TURF OIL EXTRACTOR

The unit uses a small vacuum system, which pumps fluid through a hose to the 6-liter reservoir. It also includes a pour spout to aid in emptying the reservoir. Pump is removable for easy storage.

Description	Part No.
Hydro-Turf Oil Extractor	OIL01



KN204

KN303

**NEW**



## PERFORMANCE GOLD OIL FILTER

- 1-inch nut easy-on/easy wrench-off
- Drilled safety wire holes for racing
- Heavy-duty construction
- Premium filter media provides outstanding filtration at high-flow rates

Sea Doo	OEM#	Part No.
All Sea Doo 4-stroke	420950741	KN556

Yamaha	OEM#	Part No.
FX/VX	59H-1344-0-00-00	KN303

Kawasaki	OEM#	Part No.
FX/VX	16099-004	KN204

Honda	OEM#	Part No.
Aquatrax 02-04	15410-NCJ-003	KN204



## RULE FLAT TANK ELECTRIC OIL EXTRACTOR

Eliminate those costly yard service fees with the new quick, clean, compact electric oil extractor. Includes a 3-1/2 gallon compact self-priming diaphragm pump for extraction and an easy pour spout for oil transfer.

- 3.5 gallon (13 liter) leak proof container
- Designed for ease of carrying
- Complete with dipstick, suction tube & battery clamps
- Self-priming, dry running, 12 or 24 volt diaphragm pump
- Empties and stows easily

Description	Part No.
Electric Oil Extractor	17860-0012

FUEL SYSTEMS	ENGINE/GASKETS	EXHAUST	DRIVE LINE HANDLING	ELECTRICAL	WATERLINE /BILGE	STEERING & CONTROLS	BODY	ACCESSORIES	HARDWARE	CHEMICAL	FREESTYLE & BOOSXR	FOUR STROKE
--------------	----------------	---------	---------------------	------------	------------------	---------------------	------	-------------	----------	----------	--------------------	-------------



A complete line of motor mounts designed specifically for heavy duty watercraft applications. Monkey Grip Motor Mounts are designed to be stronger than OEM mounts, yet able to dampen and isolate vibration far better than performance mounts currently available. This combination of durability and performance make Monkey Grip the right choice. Monkey Grip Motor Mounts are available for all popular watercraft.



**Sea Doo** **Part No.**  
580/650/720 All **57-1182**



**Sea Doo** **Part No.**  
800/951 Front (1 required) **57-1183F**



**Sea Doo** **Part No.**  
800/951 Rear (2 required) **57-1183R**



**Part No. 57-1152**

Yamaha Wave Runner 500	All Years
Yamaha 650 VXR	91-95
Yamaha 650LX	90-93
Yamaha 650 Wave Runner III	90-96
Yamaha 701 VXR	93-94
Yamaha 701 Wave Runner	93-00
Yamaha Wave Runner III GP	84-95
Yamaha 701 Pro VXR	93-94
Yamaha Wave Runner III 650	90-96
Yamaha Wave Raider 700	94-97
Yamaha Wave Runner III 700	97
Yamaha XL 700	99-04
Yamaha GP 800	98-00
Yamaha XL 800	00-01
Yamaha XLT 800	02-04
Yamaha GP 1200	97-99
Yamaha XL 1200	98



**Part No. 57-1172**

Yamaha Wave Blaster	93-96
Yamaha Wave Blaster II	96-97
Yamaha 700 Venture	95-96
Yamaha 701 FX	94-95
Yamaha 760 GP	97-00
Yamaha 701 Wave Raider	96
Yamaha 760 XL	98-99
Yamaha Wave Venture	97
Yamaha Wave Raider 1100	95-96
Yamaha Wave Venture 1100	96-97
Yamaha 1200 SUV	99-04



**Part No. 57-1162**

Yamaha 650 Super Jet	All Years
Yamaha 701 Super Jet	All Years



**Part No. 57-1174**

Yamaha 1200 XL LTD.	99-00
Yamaha 1200 XLT	01-05



**Part No. 57-1173**

Yamaha 1200R GPR	00-01
Yamaha 1300 GP	04-06
Yamaha FX 140	02-04
Yamaha FX 1100	04-06
Yamaha VX 1100	05-06
Yamaha FX CRUISER	04-06

FUEL SYSTEMS  
ENGINE/GASKETS  
EXHAUST  
DRIVE LINE HANDLING  
ELECTRICAL  
WATERLINE /BILGE  
STEERING & CONTROLS  
BODY  
ACCESSORIES  
SERVICE TOOLS /HARDWARE  
CHEMICAL  
FREESTYLE & 800SKR  
FOUR STROKE

FUEL SYSTEMS
ENGINE/GASKETS
EXHAUST
DRIVE LINE HANDLING
ELECTRICAL
WATERLINE /BILGE
STEERING & CONTROLS
BODY
ACCESSORIES
SERVICE TOOLS /HARDWARE
CHEMICAL
FREESTYLE & 800SXR
FOUR STROKE



**Kawasaki** **Part No.**  
450/550 All 57-1122



**Kawasaki** **Part No.**  
650/750 (Except ZXI) 57-1142



**Kawasaki** **Part No.**  
750/900/1100 ZXI,  
Ultra 150 Rear (2 required) 57-1143



**Kawasaki** **Part No.**  
Ultra 150 Front 57-1144



**Polaris** **Part No.**  
SL650 94-95, SL750 94 57-1197



**Polaris** **Part No.**  
SL650 92-93, SL700, SLT700,  
SLT750, SLT750 93, SL780,  
SLT780, SLX780, SLX785/Pro,  
SL900, SL1050, Hurricane, SLTX 57-1196



**Tiger Shark** **Part No.**  
All Models 93-95, Montego 96 57-1175  
Monte Carlo 640/900 96



01-07-511 Installation Shown

**BLAWSION**



**ENGINE KEEPERS JOE KENNEY DESIGN**

Kenney Keepers are a must have for any hardcore surf or flat-water invert artist. Each set contains a left and right side front mount retainer and extended stainless hardware for install. Our unique close tolerance design retains the front, "top heavy" weight of the engine block from being flexed or thrown forward during flat out and invert maneuvers. Since this is a common occurrence (even in flat water racing action), we have also found them to be excellent insurance against ever having to replace expensive engine mounts again.

<b>Description</b>	<b>Part No.</b>
Yamaha SJ 96t	YASJAC146
Kawasaki 750SX1/800SXR	01-07-511



2006 WORLD FINALS • LAKE HAVASU, AZ  
PHOTO COURTESY OF JIN OMURA

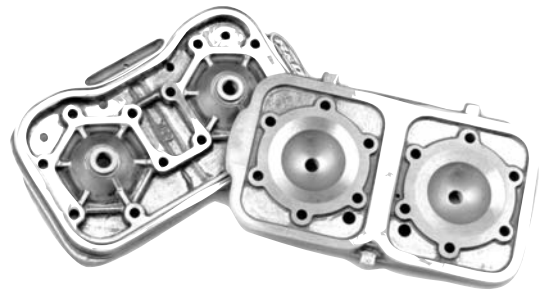

**Sea Doo 800**

Sea Doo	Part No.
800 Modified Race gas spec. 40cc	<b>413-80040</b>
800 Limited/Recreational pump gas spec. 43cc	<b>413-80043</b>

R&D Pro Series Cast CNC Machined heads are an economical alternative to the remachining of the Stock OEM Head, which many times crack and don't seal or cool properly after being modified. Pro Series Heads incorporate larger water volumes, improved circulation for superb cooling and O-Ring design for maximum sealing.



**Sea Doo 951**

Sea Doo	Head Kit	Repl. Dome	O-Ring
951 Limited 46cc	<b>413-90046</b>	<b>413-90146</b>	<b>080-95000</b>
951 Recreational 49cc	<b>413-90049</b>	<b>413-90149</b>	<b>080-95000</b>

**Yamaha 701 Ltd**



Yamaha	Part No.
701 Limited/Recreational 35cc	<b>412-70035</b>
701/760 O-Ring set of 2	<b>080-76000</b>



Kawasaki	Part No.
750/800 24cc	<b>411-75024</b>
750/800 25cc	<b>411-75025</b>
750/800 26cc	<b>411-75026</b>
750/800 27cc	<b>411-75027</b>
750 O-Ring Set of 2	<b>080-75000</b>
800 SXR 28cc	<b>411-80028</b>
800 SXR 29cc	<b>411-80029</b>
800 O-Ring Set of 2	<b>080-80000</b>
750/800 Girdle Hardware Kit	<b>411-75000</b>

\*Girdle kit is optional

**KAWASAKI 800 SX-R PRO SERIES COMPETION ENGINE HEAD KITS**

Specially designed for the Limited Racing class. The kits is complete and includes a special R&D 1.5mm base gasket.

Kawasaki	Part No.
800 SX-R 25.5cc Limited (200-210psi)	<b>411-80255</b>
800 SX-R 26.5cc Limited (190-200psi)	<b>411-80265</b>
800 SX-R 27.5cc Limited (180-190psi)	<b>411-80275</b>
800 SX-R 1.5mm Base Gasket	<b>071-00060</b>
750/800 Girdle Hardware Kit	<b>411-75000</b>



**Yamaha GP1300R**

Yamaha	Part No.
GP1300R <b>Stage 1</b> (C1=47.5, C2=46.5, C3=49cc) Variable Chamber Head	<b>412-13001</b>
GP1300R <b>Stage 2</b> (C1=46, C2=45, C3=46.5cc) Variable Chamber Head	<b>412-13002</b>
GP1300R Girdle Hardware Kit	<b>412-13000</b>
GP1200R/XLL1200 41cc	<b>412-20041</b>
GPR Head Girdle Hardware Kit	<b>412-12000</b>

\*Girdle kit is optional



Kawasaki	Part No.
Ultra 150/STX-R 1200 Recreational 42cc	<b>411-15042</b>
Ultra Head Girdle Hardware Kit	<b>411-15000</b>

FUEL SYSTEMS  
ENGINE/GASKETS  
EXHAUST  
DRIVE LINE HANDLING  
ELECTRICAL  
WATERLINE/BILGE  
STEERING & CONTROLS  
BODY  
SERVICE TOOLS ACCESSORIES/HARDWARE  
CHEMICAL  
FREESTYLE & 800SXR  
FOUR STROKE





# TBM RACING KAWASAKI 800SXR BILLET HEAD

**Kawasaki SX-R Head with Girdle Kit TBM107-G**



**Head without Girdle TBM107**



This head utilizes a three-piece design that has water flow control not possible with a one-piece head. No gaskets or messy silicone needed as it's completely sealed by o-rings. Other key features are an integrated rear pipe mount for the Factory Pipe and a girdle design that eliminates the need to machine your cylinder.

Domes are manufactured from 7057 aluminum alloy and hard anodized for even heat dissipation and corrosion protection. Domes feature a unique bowl design that is not your typical spherical configuration. Team Kawasaki has proved this design for the past two seasons.



Description	Part No.
Kawasaki SX-R Head Kit with Girdle	TBM107-G
Kawasaki SX-R Head Kit without Girdle	TBM107
Replacement O-Rings for Head Kit	TBM107-O
Girdle Head Factory Dry Pipe Hardware Kit	TBM107-FP
Dome 22cc Super Stock 220 psi+	TBM022
Dome 24cc Limited/Super Stock 215 psi+	TBM024
Dome 26cc Limited/Super Stock 210 psi+	TBM026
Dome 27cc Limited/Super Stock 195 psi+	TBM027
Dome 28.5cc Limited/Super Stock 190 psi+	TBM028.5
Dome 29.5cc Limited/Super Stock 180 psi+	TBM029.5

\* Domes Sold Individually

When the 2005 IJSBA rulebook allowed the use of up to a .060" base gasket in the limited class we went right to work designing a dome that will accommodate this change. The difference between these domes is the increased step in the squish band. A .050" step optimizes the piston clearance when using a .060" base gasket. If a thinner gasket is used the dome will require machining to avoid piston to head contact.

Description	Part No.
Limited Spec. Dome 22cc (+.050")	TBM022-L
Limited Spec. Dome 24cc (+.050")	TBM024-L
Limited Spec. Dome 26cc (+.050")	TBM026-L
Limited Spec. Dome 27cc (+.050")	TBM027-L
Limited Spec. Dome 29cc (+.050")	TBM029-L
.060" (1.5mm) Base Gasket	7040F

\* Domes Sold Individually

## MISCELLANEOUS DOMES ONLY

\*We have limited quantities on these items at a discounted price. Once these items are sold, they will be discontinued.

DOMES SETS ONLY FOR WESTCOAST PERFORMANCE HEADS			
Dome P/No	Dome Size	Compression	Head P/No
<b>Yamaha 650 Head</b>			(reference only)
YEP6524	24cc	220Lbs	YEP7000
YEP6526	26cc	210Lbs	YEP7000
YEP6527	27cc	205Lbs	YEP7000
YEP6528	28cc	195Lbs	YEP7000
YEP6529	29cc	185Lbs	YEP7000
YEP6530	30cc	180Lbs	YEP7000
<b>Kawasaki 550 82-90 Head</b>			
EP5017	17cc		EP4400
EP5021	21cc		EP4400
<b>Kawasaki 550 91+ Head</b>			
EP5517	17cc		EP5500
<b>Yamaha 700 Head</b>			
YEP7024	24cc	215 lbs	YEP7000
<b>Kawasaki 750 Head</b>			
EP75	Blank		EP7500

DOMES ONLY FOR BUCKSHOT HEAD	
<b>Sea Doo Head</b>	
50-5019-47	47.2cc
<b>DOMES ONLY FOR PRO-DESIGN HEAD</b>	
<b>Yamaha 1100 Head</b>	
50-5037-37	37cc
50-5037-39	39cc
<b>Yamaha 1200 Head</b>	
50-5043-42	42cc
50-5043-44	44cc
<b>DOMES ONLY FOR MRC (MEL MILLER) HEAD</b>	
<b>AP1200R Head *3pcs/set</b>	
50-5110-38	38cc Dome set (Race Gas)
50-5110-39	39cc Dome set (Race Gas)

FUEL SYSTEMS  
ENGINE/GASKETS  
EXHAUST  
DRIVE LINE HANDLING  
ELECTRICAL  
WATERLINE /BILGE  
STEERING & CONTROLS  
BODY  
ACCESSORIES  
HARDWARE  
CHEMICAL  
FREESTYLE & 800SXR  
FOUR STROKE



**Yamaha  
701/760**



**ADA YAMAHA 701/760 BILLET HEAD**

Yamaha	Part No.
Y701/760 Girdle Billet Head Shell**	YA701M
** Girdle Kit is not included in Head Kit	
Girdle Kit (6 pcs.) for Girdle Head **	YA701G6
Y701/760 Non-Girdle Billet Head Shell	YA701L
701-81mm 33cc (200Lbs/105 Octane)	YA2133L
701-81mm 35cc (185Lbs/92 Octane) *	YA2135L
* 35cc Dome for 100 Octane with Dry Pipe	
701-81mm 37cc (170Lbs/92 Octane)	YA2137L
760-84mm 33cc (215Lbs/110 Octane)	YA7633L
760-84mm 31cc (230Lbs/115 Octane)	YA7631L
760-84mm 35cc (200Lbs/105 Octane)	YA7635L
760-84mm 38cc (180Lbs/98 Octane)	YA7638L
760-84mm 40cc (165Lbs/91 Octane)	YA7640L
Flat Top Dome -	
4° w/.015" Relief@86mm	30cc YAK8630L15
Flat Top Dome -	
4° w/.015" Relief@86mm	28cc YAK8628L15
Flat Top Dome -	
4° w/.015" Relief@86mm	26cc YAK8626L15
Flat Top Dome -	
4° w/.015" Relief@86mm	24cc YAK8624L15
Flat Top Dome -	
4° w/.015" Relief@86mm	22cc YAK8622L15
Dome for Flat Top Kawasaki Piston @ 82mm	24cc KD1224
Exhaust Pipe Mount Bracket	YEXBRKT-2M
O-Ring Kit	ORKIT-YA701M

\*\*\*All ADA Domes are sold individually

**ADA INDIVIDUAL O-RING**

Descriptions	Part No.
A. O-Ring, Dome Top Around Spark Plug Hole	OR020
B. O-Ring Head Shell to Dome	OR024
C. Compression O-Ring Ultra 150, All Yamaha	OR043
D. Compression O-Ring SD 951	OR044
E. Outer Water O-Ring Ultra 150 (3 req.)	OR049
F. Outer Water O-Ring Y701/760	ORYA701
Compression O-Ring K750/800	OR042

**Sea Doo  
720/800**



**ADA SD720 AND 800 BILLET HEAD**

Sea Doo	Part No.
Sea Doo 720 Billet Head Shell	SD720
Sea Doo 720 34cc Dome (190 Lbs 105 oct.)	SD7234
Sea Doo 720 36cc Dome (175 Lbs 100 oct.)	SD7236
Sea Doo 800 Billet Head Shell	SD800
Sea Doo 800 39cc Dome (205 Lbs 105 oct.)	SD8039
Sea Doo 800 41cc Dome (190 Lbs 98 oct.)	SD8041
Sea Doo 800 43cc Dome (175 Lbs 91 oct.)	SD8043

\*\*\*All ADA Domes are sold individually

**Sea Doo  
951**



**ADA SD951 BILLET HEAD**

Sea Doo	Part No.
Sea Doo 951 Billet Head Shell	SD951
Sea Doo 951 46cc Dome (183 lbs-105 oct.)	SD9546
Sea Doo 951 48cc Dome (1.75 lbs-98 oct.)	SD9548
Sea Doo 951 50cc Dome (165 lbs-91 oct.)	SD9550
O-Ring Kit	ORKIT-SD951

\*\*\*All ADA Domes are sold individually

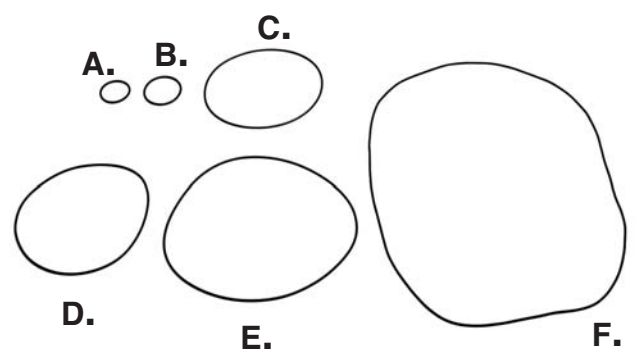

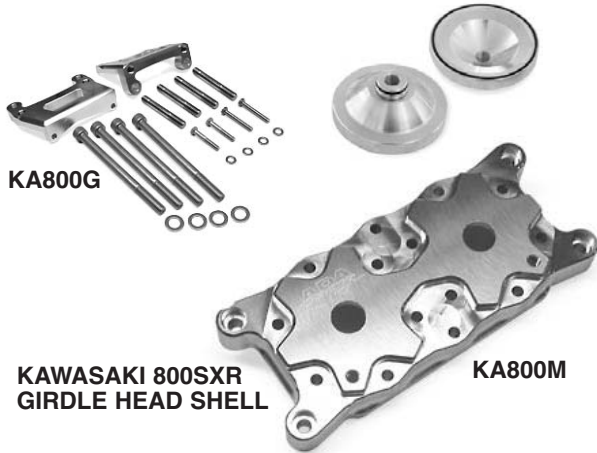

**KAWASAKI 800SXR  
GIRDLE HEAD SHELL**

**KA800M**

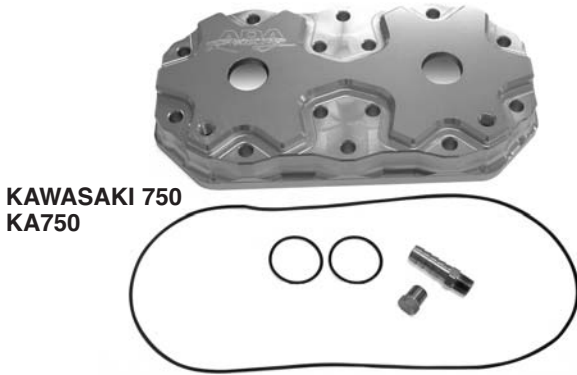

**KAWASAKI 750  
KA750**



**KAWASAKI  
ULTRA 150/STX-R  
GIRDLE HEAD SHELL KIT**  
\*DOMES SOLD SEPARATELY



## ADA KAWASAKI 800SXR BILLET GIRDLE HEAD

This head uses the stock head bolts and is completely sealed by O-rings, no head gasket required. Dual water outlets for additional cooling. This head will work with Factory Pipe's 800 dry pipe.

<b>Kawasaki</b>	<b>Part No.</b>
ADA 800SXR/750 Girdle Head Shell**	<b>KA800M</b>
ADA 800SXR Girdle Kit	<b>KA800G</b>
ADA 800SXR Dome 22cc (225 lbs.-114 Octane)	<b>KA8022</b>
ADA 800SXR Dome 24cc (216 lbs.-110 Octane)	<b>KA8024</b>
ADA 800SXR Dome 26cc (208 lbs.-105 Octane)	<b>KA8026</b>
ADA 800SXR Dome 28cc (200 lbs.-98 Octane)	<b>KA8028</b>
ADA 800SXR Dome 30cc (190 lbs.-95 Octane)	<b>KA8030</b>
ADA 800SXR Dome 32cc (180 lbs.-91 Octane)	<b>KA8032</b>
ADA 800SXR Cable Bracket to use with stock carburetors	<b>KA800BRK-CARB</b>
ADA 800SXR O-Ring Kit	<b>ORKITK750</b>

\*\*\*All ADA Domes are sold individually

## ADA KAWASAKI 750 BILLET HEAD

<b>Kawasaki</b>	<b>Part No.</b>
ADA 800SXR/750 Girdle Head Shell**	<b>KA800M</b>
ADA 800SXR Girdle Kit	<b>KA800G</b>
K750 Non-Girdle Billet Head Shell	<b>KA750</b>
K750 24cc Dome (195 lbs.-100 Octane)	<b>KA7524</b>
K750 26cc Dome (180 lbs.-92 Octane)	<b>KA7526</b>
K750 28cc Dome (165 lbs.-91 Octane)	<b>KA7528</b>
K750 30cc Dome (150 lbs.-89 Octane)	<b>KA7530</b>

\*\*ADA 800SXR Girdle Head Shell also fits Kawasaki 750 but must use the ADA 750 Domes.

\*\*\*All ADA Domes are sold individually

**KAWASAKI  
ULTRA 150/STX-R  
NON GIRDLE HEAD SHELL**



## ADA KAWASAKI ULTRA 150/STX-R BILLET GIRDLE HEAD KIT

<b>Kawasaki</b>	<b>Part No.</b>
Ultra 150/STX-R Billet Head Shell (Non Girdle Head)	<b>KU150</b>
Ultra 150/STX-R Billet Girdle Head with Girdle Hardware	<b>KA1200M</b>
44cc Dome +10 Lbs 91 Oct.	<b>KU1544</b>
42cc Dome +20 lbs 91 Oct.	<b>KU1542</b>
40cc Dome +30 lbs 98 Oct.	<b>KU1540</b>
38cc Dome +40 lbs 105 Oct.	<b>KU1538</b>
Ultra 150/STX-R O-Ring Kit	<b>ORKIT-KU150</b>

\*\*\*All ADA Domes are sold individually

## RIVA RACING HEAD O-RING KIT

<b>Head O-Ring Kit</b>	<b>Part No.</b>
2 Cylinder (701/760)	<b>RY10026-O</b>
3 Cylinder (63M/65U)	<b>RY10028-O</b>
GP800 (66E)	<b>RY100277-O</b>
GP1200R (For RY100288B/100289A1)	<b>RY100288-O</b>

FUEL SYSTEMS  
ENGINE/GASKETS  
EXHAUST  
DRIVE LINE HANDLING  
ELECTRICAL  
WATERLINE /BILGE  
STEERING & CONTROLS  
BODY  
ACCESSORIES  
SERVICE TOOLS /HARDWARE  
CHEMICAL  
FREESTYLE & 800SXR  
FOUR STROKE

## PERSONAL WATERCRAFT KITS

All pistons are high quality forged alloy and include rings, taper wall wrist pins and circlips.



The ★ column, next to the sleeve part number, will help the rebuilder identify the cylinder that is to be sleeved. The ★ column designation will also help the rebuilder to determine the proper installation procedure.

### ★ Column Code Explanations:

- AC** – Original cylinder bore is alloy-chrome plated, Nikasil, or electrofused. The cylinder must be bored to accept the new cylinder sleeve.
- CS** – Original block has a cast-in sleeve liner in the cylinder. The cylinder must be bored out to accept the new cylinder sleeve. The cast-in liner will be bored completely out of the cylinder. Do not try to push out the cast-in liner, cylinder damage may be the result.
- CI** – Original block has a cast-in liner in the cylinder. The cylinder must be bored to accept the new cylinder sleeve. When using a CI style sleeve the cast-in liner will not be completely removed. The sleeve is designed to insert into the iron lined cylinder.
- RS** – Original block has a replacement sleeve. Heat the cylinder to remove the sleeve. Reheat the cylinder to install the new cylinder sleeve.
- CC** – Original barrel is cast-iron. The cylinder must be bored to accept the new cylinder sleeve.

				L.A. SLEEVE										
Model	SEA DOO	Cyl. I.D.	★	L.A. SLEEVE	Piston Style	Piston Kit	Bore Size mm	Over Size mm	CC	Ring Set	Circlip	Wrist Pin	Wrist Pin Bearing	Big End Bearings
Sea Doo 580 (Long Finger Port)	1988	76mm	RS	FL-5102	E Coated	734M07600	76.00	STD	580	2992TD	CW18	S477	50-4185	01319
						734M07650	76.50	0.50	588	3012TD				
						734M07700	77.00	1.00	595	3032TD				
						734M07750	77.50	1.50	602	3051TD				
XP, SPI, GTX, SPX-650 (657cc)	1989-96 1993-95	78mm	RS	FL-5244	L Ring STOCK STYLE	663M07800	78.00	STD	650	3071LK	CW20	S512	50-4184 (1993) 50-4182 (94-95)	01319
						663M07850	78.50	0.50	658	3091LK				
						663M07900	79.00	1.00	666	3110LK				
						663M08000	80.00	1.50	674	3150LK				
XP, GTI, HX, SPX, GTS, GS, GSI-750 (718cc)	1995-97	82mm	RS	FL-5268	L Ring IJSBA Ltd. Class Legal	775M08200	82.00	STD	718	8200LF	CW20	S461	50-4184	01321
						775M08250	82.50	0.50	726	8250LF				
						775M08300	83.00	1.00	735	8300LF				
						775M08350	83.50	1.50	744	8350LF				
						775M08400	84.00	2.00	754	8400LF				
XP, SPX, GSX, GTX-785 Rave GTX RFI, GSX RFI-785 Rave 1995-00		82mm	RS	FL-5290	L Ring IJSBA Ltd. Class Legal	779M08200	82.00	STD	780	8200LF	CW20	S461	50-4184	01323
						779M08210	82.10	0.10	782	8210LF				
						779M08250	82.50	0.50	791	8250LF				
						779M08296	82.96	0.96	800	*8300LF				
						779M08300	83.00	1.00	801	8300LF				
						779M08350	83.50	1.50	810	8350LF				
						779M08400	84.00	2.00	820	8400LF				
GSX LTD, XP LTD, GTX LTD-951 LRV, RX 1997-00		88mm	RS	FL-5322		716M08800	88.00	STD	951	3464KD	CW21	S568	01242	B1065
						716M08850	88.50	0.50	960	3484KD				
						716M08900	89.00	1.00	971	3503KD				
						716M08940	89.40	1.40	982	3520KD				
						716M09000	90.00	2.00	993	3544KD				
						716M09100	91.00	3.00	1017	3584KD				

\* Cylinder Sleeving and Crankcase cleanup required for 91mm bore.

				<b>WISECO</b>										Wrist Pin Bearing	Big End Bearings
Model	<b>YAMAHA</b>	Cyl. I.D.	★	L.A. SLEEVE	Piston Style	Piston Kit	Bore Size mm	Over Size mm	CC	Ring Set	Circlip	Wrist Pin			
WaveJammer, WaveRunner (496cc) 1987-92		72mm	RS	YA-5025		586M07200 586M07250 586M07300 586M07350	72.00 72.50 73.00 73.50	STD 0.50 1.00 1.50	496 503 509 517	2835CD 2854CD 2874CD 2894CD	CW20	S478	50-4184	01325	
Super Jet 1990-93, WaveRunner III 1996, WaveRunner VXR 1992-95 (from 817001) (633cc) Twin		77mm	RS	YA-5139		602M07700 602M07750 602M07800 602M07850	77.00 77.50 78.00 78.50	STD 0.50 1.00 1.50	633 641 649 658	3032TD 3051TD 3071TD 3091TD	CW20	S423	50-3302	01325	
WaveRunner 91-92, WaveRunner LX 93 WaveRunner III 1990-95 WaveRunner VXR (from 816999) 91-92 (633cc) Twin		77mm	RS	YA-5176		602M07850 602M07900	78.50 79.00	1.50 2.00	658 667	3091TD 3110TD					
Super Jet, WaveRunner III GP WaveBlaster, WaveRunner II WaveRunner Pro VXR, FX700 WaveRaider 1996-97 (701cc) Twin	93-00	81mm	RS	YA-5187		790M08100 790M08150 790M08200 790M08250 790M08300	81.00 81.50 82.00 82.50 83.00	STD 0.50 1.00 1.50 2.00	701 710 718 726 735	3189KD 3209KD 3228KD 3248KD 3268KD	CW20	S512	50-3483	01325	
WaveRaider 1994-95 WaveRaider DX, WaveVenture Wave Venture XL700 (701cc)Twin	95-00	81mm	RS	YA-5284		790M08400	84.00	3.00	753	3307KD					
Super Jet, WaveRunner III GP WaveBlaster, WaveRunner II WaveRunner Pro VXR, FX700 WaveRaider 1996-97 Big Bore to 789cc Twin	93-00	84mm		YA-5187B		757M08400 757M08450 757M08500 757M08550 757M08600	84.00 84.50 85.00 85.50 86.00	STD 0.50 1.00 1.50 2.00	754 763 771 780 789	3307KD 3327KD 3347KD 3368KD 3386KD	CW20	S512	50-3483	01325	
WaveBlaster, WaveBlaster II WaveRaider, WaveRunner GP760 WaveVenture, XL760 1996-00 (754cc) Twin		84mm	RS	YA-5304											
WaveRunner GP800 1998-00 WaveRunner XL800 2000 (784cc) Twin		80mm	AC	YA-5356		758M08000	80.00	STD	784	3150KD	CW22	S640	01343		
WaveRaider 1100 1995-97 WaveVenture 1100 (1051cc) Triple		81mm	RS	YA-5282		791M08100 791M08150 791M08200 791M08250 791M08300	81.00 81.50 82.00 82.50 83.00	STD 0.50 1.00 1.50 2.00	1051 1064 1077 1090 1104	3189KD 3209KD 3228KD 3248KD 3268KD	CW20	S512	50-3483	01325	
WaveRunner GP1200 1997-99 SUV1200 1999-00 XL1200 1998 (1131cc) Triple		84mm	RS	YA-5349		757M08400 757M08450 757M08500 757M08550 757M08600	84.00 84.50 85.00 85.50 86.00	STD 0.50 1.00 1.50 2.00	1131 1142 1156 1169 1184	3307KD 3327KD 3347KD 3366KD 3386KD	CW20	S631	50-3483	01325	
XL 1200 LTD 1998-00 GP1200R 2000 (1176cc) Triple		80mm	AC	YA-5469		758M08000	80.00	STD	1176	3150KD	CW22	S640	01343		

				<b>WISECO</b>										Wrist Pin Bearing	Big End Bearings
Model	<b>TIGERSHARK</b>	Cyl. I.D.	★	L.A. SLEEVE	Piston Style	Piston Kit	Bore Size mm	Over Size mm	CC	Ring Set	Circlip	Wrist Pin			
Tigershark 640 1993-99		75.7mm	CI	FL-5237		632M07600 632M07650 632M07700	76.00 76.50 77.00	0.31 0.81 1.31	639 652 661	2992TD 3012TD 3032TD	CW20	S461	B1024		
Daytona, Monte Carlo 770, TS770, TS770L, TS770R 1996-99		83mm		FL-5298											
Tigershark 900 TS 900L 1995-96 1999		76.5mm		FL-5281		2349M07650 2349M08050	76.50 80.50	STD 4.00	896 998	3012TDW 3169TD	CW20	S512	B1024		
Daytona, Monte Carlo 1000 TS-1000R, TS-1000L 1997-98 1999		81mm		FL-5343		2394M08100 718M08500	81.00 85.00	STD 4.00	1000 1100	3189KD 3347KD	CW22	S539	B1024		
TS1100R, TS1100Li 1999		85mm		FL-5418											

### General Rules for Sleeve Installation:

These tips are intended to be a guide for installing sleeves into cylinders. There are always exceptions to the rule and care must be taken on special applications.

**ALWAYS WAIT UNTIL THE SLEEVE ARRIVES BEFORE BEGINNING ANY MACHINE WORK. NEVER ASSUME THAT THE STATED MODEL AND YEAR OF THE CYLINDER IS CORRECT. ALWAYS CHECK TO SEE IF THE SLEEVE PORTS MATCH THE CYLINDER PORTS.**

1. Interference fit for cylinder sleeve to aluminum bore is .004.
2. Interference fit for cylinder sleeve to a cast iron bore is .002 to .003.
3. Installation of flanged type sleeves follow the same rules, but the top of the cylinder must have a countersink to the correct depth to accept the flanged sleeve. .000 to .001 interference fit on the flange diameter is recommended.
4. Heating the cylinder for 45 minutes to one hour at 350 degrees to 450 degrees is preferable.
5. The sleeve should slide in very easily when the cylinder is properly heated. Freeze shrinking the sleeve is not necessary. (Some machinists believe this assists installation of the sleeve.)
6. **REMEMBER:** Rap or press the sleeve down while the cylinder is cooling down. Use a hydraulic press for this procedure.
7. Milling the top deck of the cylinder always adds a quality touch. A caution here, some cylinders may not be able to have the top surface decked.
8. For two-stroke cylinders, blending or matching the aluminum cylinder to the sleeve ports is recommended for proper fuel flow.

FUEL SYSTEMS  
ENGINE/GASKETS  
EXHAUST  
DRIVE LINE HANDLING  
ELECTRICAL  
WATERLINE /BILGE  
STEERING & CONTROLS  
BODY  
ACCESSORIES /HARDWARE  
SERVICE TOOLS  
CHEMICAL  
FREESTYLE & BOOSXR  
FOUR STROKE

L.A. SLEEVE **WISECO**

Model	KAWASAKI	Cyl. I.D.	★	Piston Style	Piston Kit	Bore Size mm	Over Size mm	CC	Ring Set	Circlip	Wrist Pin	Wrist Pin Bearing	Big End Bearings
JS-550 Iron Cylinder 1986-90	75mm	CC	KA-5033		516M07500 516M07550 516M07600	75.00 75.50 76.00	STD 0.50 1.00	531 537 544	2953TC 2973TC 2992TC	CW16	S259	50-3122	
JS-55OSX Reed 1991-95	75mm	CI	KA-5135		608M07500 608M07550 608M07600	75.00 75.50 76.00	STD 0.50 1.00	531 537 544	2953TD 2973TD 2992TD	CW16	S259	50-3122	
JS, JL, JF-650 1986-96	76mm	CS	KA-999		549M07600 549M07650 549M07700	76.00 76.50 77.00	STD .030 .040	635 643 657	2992TD 3012TD 3032TD	CW18	S513	50-3272	01315
JS-750SX, SS, ST, XiR 1992-95	80mm	CI	KA-5166		813M08000 813M08050 813M08100 813M08150 813M08200	80.00 80.50 81.00 81.50 82.00	STD 0.50 1.00 1.50 2.00	743 752 760 771 779	3150KD 3169KD 3189KD 3209KD 3228KD	CW20	S650 (20mm)	50-3302	01317
Supersport Xi 1993-95	80mm	CS	KA-5166H		813M08300 813M08500 813M08550	83.00 85.00 85.50	3.00 5.00 5.50	496 840 849	3268KD 3347KD 3367KD				
Special Heavy O.D. Sleeve 3.600" * Crankcase cleanup and cylinder sleeving required for 83mm thru 85.5mm bore.													
JS-750 SXi, ZXi 1995-00	80mm	CI	KA-5280		809M08000 809M08050 809M08100	80.00 80.50 81.00	STD 0.50 1.00	743 752 760	3150KD 3169KD 3189KD	CW22	S662 (22mm)	50-3304	B1065
STX, STS, SXi Pro, Xi Sport Supersport Xi 1996-97	80mm	CS	KA-5280H		809M08150 809M08200	81.50 82.00	1.50 2.00	771 779	3209KD 3228KD				
Special Heavy O.D. Sleeve 3.600" * Crankcase cleanup and cylinder sleeving required for 83mm thru 84.5mm bore.					809M08300 809M08400 809M08450	83.00 84.00 84.50	3.00 4.00 4.50	795 820 830	3268KD 3307KD 3327KD				
JS-750 SXi, SXi pro 1996-02	80mm			E Coated	810M08250 810M08296	82.50 82.96	2.50 2.96	791 800	8250KB 8300KB	CW22	S640	50-3304	B1065
SX800R 2003 * These racing pistons feature a cutaway skirt, boost port feed hole, and thinner rings. Kawasaki factory race part													
SX800R 2003	82mm		KA-5496		837M08200 837M08250 837M08296	82.00 82.50 82.96	STD 0.50 2.96	782 791 800	3228KD 3248KD 3268KD	CW22	S662	50-3304	B1065
JH-900 ZXi, JT-900 STX (891cc) 1995-00 triple cylinder	73mm	CS	KA-5283		659M07300 659M07350 659M07400 659M07450	73.00 73.50 74.00 74.50	STD 0.50 1.00 1.50	891 903 915 928	2874CD 2894CD 2913CD 2933TD	CW20	S512	50-3302	01317
JH-1100 ZXi, JT-1100 STX (1071cc) 1996-00 triple cylinder Not for 1100DI	80mm		KA-5303		809M08000 809M08050 809M08100 809M08150 809M08200	80.00 80.50 81.00 81.50 82.00	STD 0.50 1.00 1.50 2.00	1071 1083 1097 1106 1125	3150KD 3169KD 3189KD 3209KD 3228KD	CW22	S662	50-3304	01317
JH-1100 ZXi, JT-1100 STX Big Bore to 1180cc 1996-00	83mm		KA-5303B		809M08300 809M08400 809M08450	83.00 84.00 84.50	3.00 4.00 4.50	1151 1179 1193	3268KD 3307KD 3327KD	CW22	S662	50-3304	01317
Ultra 150 (1176cc) triple cylinder 1999-00	80mm	AC	KA-5415		749M08000 749M08050 749M08100	80.00 80.50 81.00	STD 0.50 1.00	1176 1191 1205	3150TD 3169TD 3189TD	CW24	S598	50-4186	

**SJ Flat Top Piston**  
85.0 mm for SJ 771CC  
85.5 mm for SJ 780CC  
Piston skirt must be modified to match sleeve

L.A. SLEEVE **WISECO**

Model	POLARIS	Cyl. I.D.	★	Piston Style	Piston Kit	Bore Size mm	Over Size mm	CC	Ring Set	Circlip	Wrist Pin	Wrist Pin Bearing	Big End Bearings
SL-650 1992-95	65mm	CI	FL-5191		624M06500 624M06550 624M06600 624M06650 624M06700	65.00 65.50 66.00 66.50 67.00	STD 0.50 1.00 1.50 2.00	647 656 665 675 685	2559CD 2579CD 2598CD 2618CD 2638CD	CW18	S280	50-3496	01329
Hurricane 700 1996-97	81mm		FL-5300		700M08100	81.00	STD	700	3189TD	CW20	S512	50-4182	
SL, SLT-700 1996-97	81mm	RS	FL-5341		700M08150 700M08200 700M08250 700M08300	81.50 82.00 82.50 83.00	0.50 1.00 1.50 2.00	710 718 726 734	3209TD 3228TD 3248TD 3268TD				
SLH, SLTH-700, Virage (65H) (700cc) twin Freedom 1998-02 2002													
SL, SLT-750 1993-95	69.75mm	CI	FL-5239		633M06975 633M07025 633M07075 633M07125 633M07150 633M07200	69.75 70.25 70.75 71.25 71.50 72.00	STD 0.50 1.00 1.50 1.75 2.25	744 755 766 777 783 795	2746CD 2766CD 2786CD 2805CD 2815CD 2835CD	CW18	S343	50-3496	01329
Special Heavy O.D. 80.60mm	69.75mm	CS	FL-5239H										
SL, SLT, SLX-780 triple cylinder 1995-97	71.5mm		FL-5302		633M07150 633M07200	71.50 72.00	0.20 0.71	783 794	2815CD 2835CD	CW18	S343	50-3496	01329

Model	POLARIS	Cyl. I.D. ★	L.A. SLEEVE	Piston Style	Piston Kit	Bore Size mm	Over Size mm	CC	Ring Set	Circlip	Wrist Pin	Wrist Pin Bearing	Big End Bearings
SLX Pro 785 (779cc) triple cylinder	1997-00	69.72mm	FL-5342	XPS E-Coated	722M06970	69.70	STD	799	2746CD	CW18	S343		
* Nikasil Bore - Cylinder Sleaving or Replating Required for Oversizes.													
Octane 777 Virage I	2002 2002	84mm	FL-5416	E-Coated	811M08400 811M08450 811M08500 811M08525	84.00 84.50 85.00 85.25	STD .050 1.00 1.25	775.8 785.1 794.4 799.1	8400KB 8450KB 8500KB 8520KB	CW22	S662		
<i>Low Dome Race Part. (Flat Top) Head Modifications required.</i>													
SL-900 triple cylinder	1996-97	74.5mm	FL-5305	RS	687M07450 687M07500 687M07550 687M07600 687M07650	74.50 75.00 75.50 76.00 76.50	STD 0.50 1.00 1.50 2.00	889 901 913 925 937	2933TD 2953TD 2973TD 2992TD 3012TD	CW20	S512	50-4182	
SL, SLX, SLTC, SLXH-1050 (1051cc) triple cylinder	1996-99	81mm	FL-5297		781M08100 781M08150 781M08200 781M08250 781M08300	81.00 81.50 82.00 82.50 83.00	STD 0.50 1.00 1.50 2.00	1051 1064 1077 1090 1102	8100LF 8150LF 8200LF 8250LF 8300LF	CW20	S512	50-4182	
Pro1200, Virage TX Virage TXI, SLX Genesis all Models X45	2000-01 99-02 1999	84mm	FL-5416		811M08400 811M08450 811M08500 811M08525	84.00 84.50 85.00 85.25	STD 0.50 1.00 1.25	775.8 785.1 794.4 799.1	8400KB 8450KB 8500KB 8525KB	CW22	S662		
Pro1200, Virage TX Virage TXI	2001-02				812M08500 812M08525	85.00 85.25	1.00 1.25	794.4 799.1	8500KB 8525KB	CW22	S662		
<i>Low Dome Race Part. (Flat Top) Head Modifications required.</i>													

MODEL	L.A. SLEEVE	CUBIC DISPLACEMENT	CYLINDER I.D.	CODE	PART NO.
-------	-------------	--------------------	---------------	------	----------

<b>Sea Doo</b>					
580 (Long Finger Port) 1988		580cc	76mm	RS	FL-5102
580 (Short Finger Port) 1989-96		580cc	76mm	RS	FL-5125
XP/SPI, GTX, SPX 1993-95		650cc	78mm	RS	FL-5244
GTI, HX, SPX, XP, GTS, GS, GSI		718cc	82mm	RS	FL-5268
XP/SPX/GTX RFI-785 Rave 1995-02		782cc	82mm	RS	FL-5290
GSX/XP/GTX-951 LTD RX 1997-02		951cc	88mm	RS	FL-5322

<b>Polaris</b>					
SL-650 1992-95		647cc	65mm	CI	FL-5191
Hurricane 700 1996-97		700cc	81mm		FL-5300
SLT/SLH/SLTH-700 1996-98		700cc	81mm	RS	FL-5341
SL-750 1993-95		744cc	69.7mm	CI	FL-5239
SL, SLT, SLX-780 1995-97		783cc	71.5mm		FL-5302
SLX Pro 785 1997-01			69.72mm	AC	FL-5342
SL-900 1996-97		889cc	74.5mm	RS	FL-5305
SLTX/SLXH-1051 1996-99		1051cc	81mm		FL-5297
Virage, Octane 777 2002		777cc	84mm	RS	FL-5416
Genesis 1200 (99-02), SLX, X-45 1200, Pro 1200, Virage TX & TXI 1999-02		1165cc	84mm	RS	FL-5416

<b>Yamaha</b>					
Wave Jammer, Wave Runner 1987-92		496cc	72mm	RS	YA-5025
Wave Runner, Super Jet thru 1993		633cc		77mm RS	YA-5139
Wave Runner LXII VXR 1991-96		633cc		77mm RS	YA-5176
61X Wave Blaster, WRIII, FX, Pro VXR, Superjet (93-07)		701cc	81mm	RS	YA-5187
Super Jet, Wave Blaster Big Bore to 62T 701 Wave Raider (94-95), Wave Venture XL 700 (95-02)		789cc 701cc	84mm 81mm		YA-5187B YA-5284
Wave Raider, WBII, GP 760/Wave Blaster (96-00)		754cc	84mm	RS	YA-5304
Wave Runner GP-800 (98-02), XL/XLT 800 (00-02)		784cc	80mm	AC	YA-5356
1100Wave Raider (95-96), Wave Venture (96-97)		1051cc	81mm	RS	YA-5282
GP1200( 97-99)/XL 1200 (98)		1131cc	84mm	RS	YA-5349
XL1200 Ltd/GP1200R		1176cc	80mm	AC	YA-5469
GP1300R (03-07)		1296cc	84mm	AC	YA-5502

<b>Kawasaki</b>					
JS-550 Iron Cylinder 1986-90		531cc	75mm	CC	KA-5033
JS-550 SX Reed 1991-95		531cc	75mm	CI	KA-5135
JS, JF-650 1986-96		635cc	76mm	CS	KA-999
JS-750 SX/SS (92-95)		743cc	80mm	CI	KA-5166
JS-750 SX/SS (92-95) Special Heavy OD Sleeve 3.600"		743cc	80mm	CS	KA-5166H
JS-750 SXI, ZXI (96-97), ST (94-95) SXI Pro		743cc	80mm	CI	KA-5280
JS-750 SX, ZXI (95-97), ST (94-95), SXI Pro Special Heavy OD Sleeve 3.600"		743cc	80mm	CS	KA-5280H
JS-900 ZXI, STX (95-06)		891cc	73mm	CS	KA-5283
JS1100ZXI, STX (96-02)		1071cc	80mm	CI	KA-5303
JS-1100 ZXI, STX (96-02) Big Bore to 800 SXR 2003-07		1180cc	83mm		KA-5303B KA-5496
Ultra 150 1999-00		1176cc	80mm	AC	KA-5415

**FUEL SYSTEMS**  
**ENGINE/GASKETS**  
**EXHAUST**  
**DRIVE LINE HANDLING**  
**ELECTRICAL**  
**WATERLINE /BILGE**  
**STEERING & CONTROLS**  
**BODY**  
**ACCESSORIES**  
**SERVICE TOOLS**  
**CHEMICAL**  
**FREESTYLE & BOOSXR**  
**FOUR STROKE**



## NIKS/PRO-X PISTON KITS

Niks/Pro-X Piston Kits are manufactured in Japan and are designed to be an O.E.M. replacement. The aluminum alloy used in the manufacturing of Pro-X pistons maintains or exceeds the factory specifications. Additional oversizes are available in .010 increments up to .080 (2.00 mm).

\* - Rings are available for all pistons. For Rings Part Number, put "R" after piston part number.

		STD	.010	.020	.030	.040	.050	.060	.070	.080	TOP END BEARINGS
<b>SEA DOO</b>	Std. Bore	STD	.25mm	.50mm	.75mm	1mm	1.25mm	1.5mm	1.75mm	2mm	
580 All thru 1996	76.00	8020	8021	8022	8023	8024		8026			50-4185
720 HX, XP, GTS, GS SPX, GTI, GSI '1995-02	82.00	8040	8041	8042	8043	8044		8046			50-4184
800 XP GSX, GTX, RFI SPX 1995-02	82.00	8050	8051	8052	8053	8054		8056			50-4184
951 XPL, GSXL, GTXL, RX, LRV 1997-07	88.00	8060	8061	8062	8063	8064					01343

		STD	.010	.020	.030	.040	.050	.060	.070	.080	TOP END BEARINGS
<b>YAMAHA</b>	Std. Bore	STD	.25mm	.50mm	.75mm	1mm	1.25mm	1.5mm	1.75mm	2mm	
650 All Thru 1996	77.00		7101		7103		7105	7106			50-3302
701 All Thru 2007	81.00	7090	7091	7092	7093	7094		7096		7098	50-3483
760 All Thru 1998	84.00	7110	7111	7112	7113	7114		7116		7118	50-3483
1100 Wave Raider '95-97 Wave Venture 1996-97	81.00	7090	7091	7092	7093	7094		7096		7098	50-3483
1200/GP1200 All thru '98	84.00	7110	7111	7112	7113	7114		7116		7118	50-3483
800 All thru 2002	79.90	7170A									01343
GP1200 R 2000-02	79.91	7170B									
XL1200 LTD 1998-00	79.92	7170C									
XLT1200 2001-02											
GP1300 R 2003-07	83.90 83.91 83.92	7190A 7190B 7190C									

		STD	.010	.020	.030	.040	.050	.060	.070	.080	TOP END BEARINGS
<b>KAWASAKI</b>	Std. Bore	STD	.25mm	.50mm	.75mm	1mm	1.25mm	1.5mm	1.75mm	2mm	
JS-440 1976-90	68.00		4451		4453	4454	4455	4456	4457	4458	50-3122
JS-550 1982-90	75.00				4463		4465	4466	4467	4468	50-3122
JS, JF-650 1986-96	76.00	4470	4471		4473		4475		4477	4478	50-3272
JS-750 SS, XS, Xi 1993-97	80.00	4480	4481	4482	4483	4484		4486	4487	4488	50-3302
JS-750 ZXi, SXi '95-98	80.00	4490	4491	4492	4493	4494		4496			50-3304
800SX-R 2003-07	82.00	4510	4511	4512	4513	4514					50-3304
JS-900 ZXi, STX 1995-06	80.00	4500	4501	4502	4503	4504	4505	4506			50-3302
JS-1100 ZXi 1996-98	80.00	4490	4491	4492	4493	4494	4495	4496			50-3304
Ultra 180 99-05	79.87	4520A									50-4186
STX-R1200 2002-05	79.88 79.89	4520B 4520C									

FUEL SYSTEMS

ENGINE/GASKETS

EXHAUST

DRIVE LINE HANDLING

ELECTRICAL

WATERLINE /BILGE

STEERING & CONTROLS

BODY

SERVICE TOOLS ACCESSORIES /HARDWARE

CHEMICAL

FREESTYLE RACING

FOUR STROKE



## TOP END (WRIST PIN) BEARINGS



Sea Doo	OEM No.	Size	Part No.
580	1988-96 290.832.320	18x22x22	50-4185
650	1993 290.832.440	20x24x23	50-4184
650	1994-95	20x25x21.7	50-4182
720	1995-02 290.832.420	20x24x23	50-4184
785	1995-02 290.832.420	20x24x23	50-4184
951	1997-02 290.832.550	21x25x24	01242

Yamaha	OEM No.	Size	Part No.
500	1987-92	20x24x23	50-4184
650	thru 1996 933310-320U200	20x25x25	50-3302
701, 760	thru 2002	20x25x24	50-3483
1100	1995-97	20x25x24	50-3483
1200 (65U)	1997-02	20x25x24	50-3483
800	1998-02	22x27x23	01343
1200 (66V)	1998-02	22x27x23	01343

Kawasaki	OEM No.	Size	Part No.
300	1986-93 13033-1010	18x22x24	50-3272
440	1977-92 13033-3005	16x20x22.5	50-3122
550	1982-95 13033-3005	16x20x22.5	50-3122
650 SX,X2,TS,SC	1986-96 13033-1010	18x22x24	50-3272
750 ST,SX,SS,XiR,Supersport Xi	1992-95 13033-3702	20x25x25	50-3302
900 ZXI,STX	1995-06 13033-3702	20x25x25	50-3302
750 ZXI,STX,SXi,STS,Xi Sport,SXi Pro,Supersport Xi	1996-02 13033-3703	22x27x24.7	50-3304
800 SXR	2003-07	22x27x24.7	50-3304
1100 ZXI,STX	1996-02 13033-3703	22x27x24.7	50-3304
Ultra 150,STX-R	13033-3704	24x29x25	50-4186

Polaris	OEM No.	Size	Part No.
650	1987-92 3083216	18x23x21.5	50-3496
750	1987-92 3083216	18x23x21.5	50-3496
780	1987-92 3083216	18x23x21.5	50-3496
700	1995-97 3584001	20x25x21.7	50-4182
900	1997-02 3584001	20x25x21.7	50-4182
1050	1998-02 3584001	20x25x21.7	50-4182
Tiger Shark	Size	Part No.	
640/900/1000	1993-99 20X26X24	B1024	

## BIG END (CRANK PIN) BEARINGS

Sea Doo	Size	Part No.
580, 650	24 x 30 x 16.75	01319
720	26 x 33 x 18	01321
785	28 x 35 x 18	01323
951	28 x 36 x 20	B1065

Yamaha	Size	Part No.
650, 701, 760, 1100	25 x 32 x 20	01325



Kawasaki	Size	Part No.
JS/JF-650	24 x 32 x 20	01315
JS750 93-95	26 x 34 x 20	01317
JS750 96-02	28 x 36 x 20	B1065
JS900ZXI	24 x 34 x 20	01317
JS1100ZXI	24 x 34 x 20	01317

Polaris	Size	Part No.
650, 750, 780	24 x 32 x 16	01329

## HOT ROD THRUST WASHERS

Determine part number by size. Refer to Dimension Chart on Page 52.

ID Size	Thickness	Part No.
24mm X	1mm	W106
25mm X	1mm	W111
26mm X	1mm	W113
27mm X	1.5mm	W115
28mm X	1mm	W116
32mm X	1mm	W118



## THRUST WASHERS

Determine part number by size. Refer to Dimension Chart on Page 52.

ID Size	Thickness	Part No.
24mm X	1mm (coated)	TW4942
25mm X	1mm	TW4968
26mm X	1mm	TW1574

2006 WORLD FINALS  
LAKE HAVASU, AZ  
PHOTO COURTESY OF  
JIN OMURA



FUEL SYSTEMS  
ENGINE/GASKETS  
EXHAUST  
DRIVE LINE HANDLING  
ELECTRICAL  
WATERLINE /BILGE  
STEERING & CONTROLS  
BODY  
ACCESSORIES  
SERVICE TOOLS /HARDWARE  
CHEMICAL  
FREESTYLE & BOOSXR  
FOUR STROKE

FUEL SYSTEMS  
ENGINE/GASKETS  
EXHAUST  
DRIVE LINE HANDLING  
ELECTRICAL  
WATERLINE /BILGE  
STEERING & CONTROLS  
BODY  
ACCESSORIES  
SERVICE TOOLS /HARDWARE  
CHEMICAL  
FREESTYLE & 800SX  
FOUR STROKE

## HOT PRODUCTS CONNECTING RODS



Heavy duty replacement rods are used in many racing applications because of proven reliability. Kits are complete with top and bottom roller bearings, pin and shims. Made in Japan.



Sea Doo	Part No.	Yamaha	Part No.
580	50-3520	500	50-3480
720 (PTO)	50-3522	650/701/760/1100/1200 (97-98)	50-3490
720 (MAG)	50-3523	GP800R/XL800/GP1200R/XL1200	50-3495
785	50-3524		
951	50-3525		
Kawasaki		Part No.	
		450/550 All	50-3120
		650 All	50-3270
		750 1992-95, 900ZXI	50-3280
		750ZXI/SXI/STS/STX/SS/XI 1996-02	50-3281
		800 SX-R	50-3281
		1100 ZXI/STX 1995-98	50-3282

## IMS PRO SERIES CONNECTING RODS

IMS Pro Series Rods are forged from SCM 415 Chromoly Steel, then deburred with a double vibrating, double honing process and then polished to perfection to insure continued performance at high RPM. NRB Bearings are double silver coated to displace excessive heat.



Sea Doo	Part No.	Polaris	Part No.
580	420501	750 Long Pin (PTO)	42101-L
650	420502	750 Short Pin (Mag. Middle)	42101-S
720 Long Pin	420503-L		
720 Short Pin	420503-S		
800	420504	<b>Kawasaki</b>	
951	420505	440/550	423104
		650	423105
		750 93-94	423106
		750ZXI/SXI 95-97	423111
Yamaha	Part No.		
650/701/1100/1200 (97-98)	427304		

## PERSONAL WATERCRAFT CONNECTING ROD DIMENSIONS

Model	Center to center mm	Small end bore mm	Big end bore mm	Small end Width mm	Big end Width mm	Pin dia. mm	pin length mm	Small end bearing mm	Big end bearing mm	Washer Thickness mm
<b>KAWASAKI</b>										
JS 440/550	110	20	30.6	18	15	24.6	49	16X20X23	24.6X30.6X15	1
JS/JF 650	133	22	32	22	20	24	59	18X22X24	24X32X20	1
JS 750 (93-96) 20mm wrist pin	133	25	34	22	20	26	59	20X25X25	26X34X20	1
JS 750 (95-00) 22mm wrist pin	133	27	36	22	20	28	58	22X27X25	28X36X20	1
JS 900 ZXI	133	25	34	22	20	26	59	20X25X25	26X34X20	1
JS 1100 ZXI, SXI (95-00)	135	27	34	22	20	26	59	22X27X25	26X34X20	1
Ultra 150	140	29	40	22	20	32	62	24X29x25	32x40x20	1
<b>POLARIS</b>										
650/750/780 SL MAG/center	120	23	32.3	16	16	24.3	51	18X23X22	24.3X32.3X16	1
650/750/780 SL PTO	120	23	32.3	16	16	24.3	54	18X23X22	24.3X32.3X16	1
700/900/1050	136	25	35	16	16	28	60	20X25X22	28X35X16	1
<b>SEA DOO</b>										
580 thru (96)	125	22	31	17	17	24	52	18X22X22	24X31X17	1
650 thru (97)	125	25	31	17	17	24	52	20X25X22	24X31X17	1
720 XP, HX MAG (95-00)	125	24	33	18	18	26	53	20X24X22	26X33X18	1
720 XP, HX PTO (95-00)	125	24	33	18	18	26	55	20X24X24	26X33X18	1
785 XP RAVE (all)	140	24	35	18	18	28	55	20X24X23	28X35X18	1
951 RAVE (98-00)	140	25	36	20	20	28	57	21X25X24	28X36X20	1
<b>YAMAHA</b>										
650/901/760/1100 (all)	125	25	32	20	20	25	60	20X25X24	25X32X20	1
GP800, GP1200R	135	27	34	21	21	27	69	22x27x23	29x34x21	1.5



## CRANK SHAFT BEARING KITS



Description	Part No.
Crank Bearing (4) Kit Kaw JS440/550	LA081572
Crank Bearing (4) Kit Kaw JS650 (86-89)	LA081573
Crank Bearing Kit Kaw JS750/800SXR	LA081574
Crank Bearing Kit Kaw JS900/1100	LA081575
Crank Bearing Kit Kaw JH1200, Ultra 150	LA081576
Crank Bearing Kit Sea Doo 580 (88-96)	LA082522
Crank Bearing Kit Yam 650/701/760	LA082531
Crank Bearing Kit Yam WR1100, GP1200	LA082532
Crank Bearing Kit Sea Doo 650, 720	LA082533
Crank Bearing Kit Sea Doo 785	LA082535
Crank Bearing Kit Sea Doo 951	LA082536
Crank Bearing Kit Polaris 650/750/780/785	LA082540
Crank Bearing Kit Polaris 700	LA082541
Crank Bearing Kit Polaris 900/1050	LA082542

## HOT ROD CONNECTING RODS

Hot Rods are double forged to improve grain flow and maintain dimensional consistency.

Sea Doo	Part No.	Yamaha	Part No.
580 1990-96	HR8166	650/701/760/1100/1200	HR8169
650 1997	HR8117	(97-98)	
720 1995-02 MAG	HR8116	GP800/GP1200R	HR8606
720 1995-02 PTO	HR8168		
785	HR8123	Kawasaki	Part No.
951 1998-05	HR8601	650 All	HR8113
951 Direct Injection	HR8628	750 (92-95), 900 ZXI	HR8114
		750 (96-02), 800 03-07	HR8131
		1100ZXI (95-00),STX	HR8138
		Ultra 150 (99-05),	HR8607
		STX R (02-05)	



## CRANK SHAFT REPLACEMENT BEARINGS



Sea Doo	FRONT MAG. #1	FRONT MAG. #2	INNER #1	INNER #2	REAR PTO#1	REAR PTO#2
580 87-94	6206NR	6206NR	6305NR	6206NR	6207NC4	6207NC4
580 95-96	6206NC4	6206NC4	6305NR	6206NR	6207NC4	6207NC4
650 93	6206NR	6206NR	6206NC4	6206NC4	6207NC4	6207NC4
650 94-96	6206NC4	6206NC4	6206NC4	6206NC4	6207NC4	6207NC4
720 all	6206NC4	6206NC4	6206NC4	6206NC4	6207NC4	6207NC4
800 all	6207NC4	6207NC4	6207NC4	6207NC4	6306NR	6207NC4
951 all	6208NC4	6208NC4	6306NC4	6208NC4	6208NC4	6208NC4

Yamaha						
650/701/760			6207YR	6207YR		
1100/1200			6207YR	6207YR		

  

Kawasaki						
440/550	6206NR		6305N	6305N	6206N	
650/750	6306C3		6306C3	6306NR	6306C3	
900/1100/Ultra	5207-1LT		6207NLT	83A844A (3)	83A948	

Polaris						
650/701/780	6207NC4	6207NC4	6207NC4(2)	6307NR		
700/900/1050	6207NC4	6207NC4	6207NC4	6207NC4	6207NC4	6207NC4

## CRANKSHAFT PARTS FOR SEA DOO

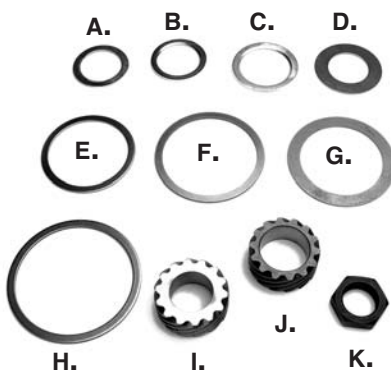

Descriptions	Models	OEM No.	Part No.
A. Distance Ring	720 Mag side – 1.5mm thick	290-827-447	010-474
B. Distance Ring	580/650 Mag side – 2mm thick	290-827-440	010-472
C. Distance Ring	580/650/720 Pto side		
	800 Mat & Pto – 2mm thick	290-827-760	010-473
D. Flat Bearing Washer	580/650 (Small)	420-827-715	010-475
E. Retainer Shim	720 (Small)	420-827-050	010-476
F. Retainer Shim	720 (Medium)	420-827-050	010-477
G. PTO Seal Retaining Ring	580/650/720/800 (Large)	420-827-715	010-479
H. Thrust Washer	951		010-470
I. Crank Center Gear	580		010-471-01
J. Crank Center Gear	650/720/800		010-471
K. Flywheel Nut	All Models	420-842-230	010-480

FUEL SYSTEMS  
ENGINE/GASKETS  
EXHAUST  
DRIVE LINE HANDLING  
ELECTRICAL  
WATERLINE /BILGE  
STEERING & CONTROLS  
BODY  
ACCESSORIES  
SERVICE TOOLS  
HARDWARE  
CHEMICAL  
FREESTYLE & 800SXR  
FOUR STROKE



## HOT RODS NEW COMPLETE CRANKSHAFT ASSEMBLIES

All new assembly. Crankshafts are sold complete with Hot Rods Connecting rods, main bearings and inner crankshaft webs. Trued to within .001. Crankshafts are completely rebuildable.

Sea Doo	Crank Assy.
580 All	HR4008
720 All	HR4009
785 1996-04 (will not fit fuel injection models)	HR4010
951 All Carburetor Models	HR4051
951 All Injection Models	HR4052

Yamaha	
650/701/760 All	HR4003
1100 Triple (63M)	HR4104
1200 Triple (65U) (No mag end bearing)	HR4004

Kawasaki	
750 96-02, 800 SX-R 03-07	HR4061

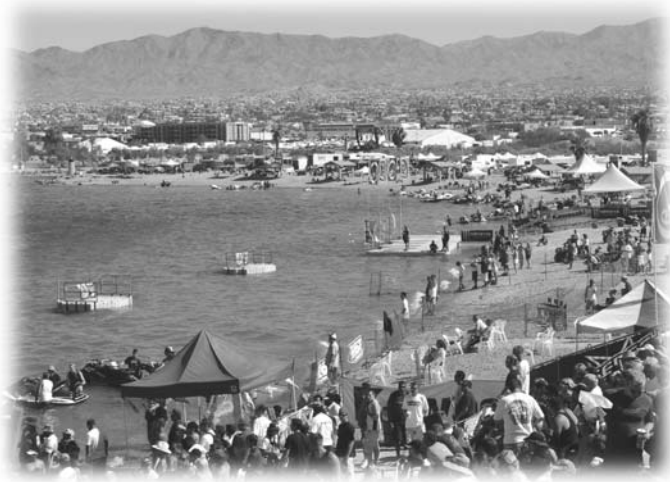

2006 WORLD FINALS • LAKE HAVASU, AZ  
PHOTO COURTESY OF JIN OMURA



## CRANKSHAFT WEBS

OEM Kawasaki 650/750 and Yamaha cranks are non-rebuildable. In order to rebuild these crankshafts the crankshaft webs must be replaced.

Yamaha	Part No.
650/701/760/1100/1200	HR201

Kawasaki	
750 93-94 (26mm Crank Pin)	HR202
650	HR203
750ZXI/SXI (28mm Crank Pin)	HR205
900 All, 1100 97-98	HR206

\*Web Kit contains 2 webs without crank pin.



## CRANKSHAFT OIL SEAL KIT

Hot Products has researched and tested these crank case seal kits to ensure the highest of quality and durable seals on the market. These seals are a direct replacements for the OEM seals. Why risk an engine failure or a short seal life with low cost seals when Hot Products has these seals in stock and ready for installation in your customers engine.

Sea Doo	Part No.
580	51-0068
650/720	51-0069
785	51-0072
951 Outer Seals Only	51-0073
951 Inner Seals Only	51-0073B

Polaris	Part No.
650/750/780/785	51-0074

Yamaha	Part No.
500 87-90	51-0048
650/701/760/1100/1200	51-0054
800	51-0057
GP1200R	51-0058

Kawasaki	Part No.
440 73-80 (Full Circle)	51-0014
440 81-91/550 ALL	51-0015
650/750 ALL	51-0027
900/1100	51-0029

# HOT PRODUCTS GASKET SETS

Hot Products gasket sets consist of superior quality gaskets for engine rebuilders and the hi-performance personal watercraft market.

Hot Products offers top end and complete gaskets sets.

Made in the USA.



Sea Doo	Top	Complete
580 -91 Yellow Eng.SP/XP/GT	6400	6425
580 92+ White Eng.SP/SPI/XP/GTS	6440	6465
650 GTX/XP/XPI/SPX	6480	6500
720 SPX/GTI/HX	6600	6610
785 XP/GSX/GTX	6620	6640
800 DI	6850	6855
951 97 GSX LTD White Eng.	6825	6830
951 98 XP LTD, GSX LTD Silver Eng	6840	6842
951 DI.	6875	6880

Polaris	Top	Complete
650	4200	4210
750	4220	4230
700 Hurricane, Virage, Freedom	4375	4378
Octane 777		4860
780	4235	4240
785/Pro	4250	4260
900	4380	4383
1050	4385	4390
1200 Genesis	4394	4395



Yamaha	Top	Complete
WJ/WR500	-	51-4803
SJ/WRIII/VXR650 (90-93)	2600	2650
LX650 (90-93)	-	51-5703
701SJ-95, BLST-95, 701W/Raider 96+	2700	2750
701SJ 96+, BLST 96+	2550	2555
701W/RDR 94-95/Venture 95+	2950	2980
760W/RDR 96+/BLST II 96+/XL760	2990	2992
800 GP 98+	3520	3530
1100Raider/Venture	4520	4530
1200 GP, XL1200	4680	4685
GP1200R, XL1200LTD	3730	3740
GP1300R	3800	3810

Kawasaki	Top	Complete
440 77-80	-	51-1203
440 81-92	-	51-1503
550 82-85	5550	5560
550 86-90	5570	5580
550SX 91-95	-	51-2403
650 All	-	5940
650 X2, TS	-	5960
750 All/800SXR	7200	-
750 SX/SXI/SXI Pro	7200	7210
750 SS/XI	7200	7220
750 SS 92-93	7200	7240
750 XIR	7200	7230
750 95 STS	7200	7225
750 ZXI 95+	7200	7245
800 SXR 03-07	7300	7310
900 ZXI 95+	7500	7520
1100 ZXI 96-98	7670	7680
Ultra 150 99+	7830	7835

Tiger Shark	Top	Complete
639	3100	3110
644	3100	3120

**\*\* Hot Products Complete Gasket Sets do not include bottom end engine seals.**

## INDIVIDUAL GASKETS FOR SEA DOO

### 580 PRE '92 SP/XP/GT (Yellow Engine)

YELLOW ENGINE	OEM No.	Part No.
Top Kit	Yellow Engine	6400
Complete Kit	Yellow Engine	6425
Head Cover O-Ring	290-950-050	6200*
Spark Plug O-Ring (2 required)	290-430-782	6220*
Cylinder O-Ring (2 required)	290-850-540	6170*
Water Jacket O-Ring (2 required)	290-850-040	6230*
Base Gasket	290-931-160	6000*
Carb Gasket 38mm (2 required)	290-842-040	6100*
Exhaust Gasket (2 required)	290-850-630	6050*
Headpipe Gasket	290-950-250	6140*
Starter Gasket	290-950-905	6120
Water Dist	290-831-612	6110
Water Mani O-Ring (2 required)	290-430-460	6240*
Flywheel Housing	290-850-600	6125
Rotary Valve Shaft O-Ring	290-831-500	6260
Rotary Valve Cover O-Ring	290-831-360	6250
Manifold O-Ring (2 carb)	290-831-705	6270
Manifold O-Ring (1 carb)	290-850-160	6275
Flywheel Cover O-Ring	290-950-130	6280

### 580 '92+ SP/SPI/XP/GTS (WHITE ENGINE)

WHITE ENGINE	OEM No.	Part No.
Top Kit	White Engine	6440
Complete Kit	White Engine	6465
Head Cover O-Ring	290-950-360	6205*
Spark Plug O-Ring (2 required)	290-430-782	6220*
Cylinder O-Ring (2 required)	293-300-026	6170*
Water Jacket O-Ring (2 required)	290-850-040	6230*
Base Gasket	290-931-161	6020.3*
Carb Gasket 38mm (2 required)	290-850-373	6100*
Carb Gasket 39mm (2 required)	270-000-114	6105*
Exhaust Gasket (2 required)	290-850-635	6060*
Headpipe Gasket	290-950-251	6150*
Starter O-Ring	278-000-694	6152
Flywheel Housing	290-850-605	6130
Rotary Valve Shaft O-Ring	293-300-023	6250
Rotary Valve Cover O-Ring	293-300-024	6260
Manifold O-Ring (2 carb)	290-831-705	6270
Flywheel Cover O-Ring	290-831-555	6278

**\* Denotes when the gasket is included in the Top End Gasket Set.**

FUEL SYSTEMS  
ENGINE/GASKETS  
EXHAUST  
DRIVE LINE HANDLING  
ELECTRICAL  
WATERLINE /BILGE  
STEERING & CONTROLS  
BODY  
ACCESSORIES  
SERVICE TOOLS  
HARDWARE  
CHEMICAL  
FREESTYLE & 800SXR  
FOUR STROKE

# INDIVIDUAL GASKETS FOR SEA DOO

## 951 97+ GSX LTD, XP LTD

**FUEL SYSTEMS**  
**ENGINE/ GASKETS**  
**EXHAUST**  
**DRIVE LINE HANDLING**  
**ELECTRICAL**  
**WATERLINE /BILGE**  
**STEERING & CONTROLS**  
**BODY**  
**ACCESSORIES**  
**SERVICE TOOLS /HARDWARE**  
**CHEMICAL**  
**FREESTYLE & 800SX**  
**FOUR STROKE**

### 650 GTX/XP/XPI/SPX

	OEM No.	Part No.
Top Kit		6480
Complete Kit		6500
Head Cover O-Ring	290-950-320	6210*
Spark Plug O-Ring (2 required)	290-430-782	6220*
Cylinder O-Ring (2 required)	290-931-220	6180*
Water Jacket O-Ring (2 required)	290-850-045	6235*
Base Gasket (.012/0.3mm)	290-931-161	6020.3
Base Gasket (.017/0.4mm)	290-931-162	6020.4
Base Gasket (.020/0.5mm)	290-931-163	6020.5*
Base Gasket (.024/0.6mm)	290-931-164	6020.6
Base Gasket (.030/0.8mm)	290-931-165	6020.8
Carb Gasket 38mm (2 required)	290-850-373	6100*
Exhaust Gasket (2 required)	290-850-637	6080*
Headpipe Gasket	290-950-251	6150*
Starter O-Ring	278-000-694	6152
Flywheel Housing	290-850-605	6130
Rotary Valve Cover O-Ring	293-300-023	6250
Rotary Valve O-Ring	293-300-024	6260
Manifold O-Ring (2 carb)	290-831-705	6270
Flywheel Cover O-Ring	290-831-555	6278

### 720 SPX/GTI/HX/GTS/GS

	OEM No.	Part No.
Top Kit		6600
Complete Kit		6610
Head Cover O-Ring	290-950-360	6205*
Spark Plug O-Ring (2 required)	290-430-782	6220*
Cylinder O-Ring (2 required)	290-931-410	6185*
Water Jacket O-Ring (2 required)	290-850-045	6235*
Base Gasket (.012/0.3mm)	290-931-400	6025.3
Base Gasket (.017/0.4mm)	290-931-401	6025.4
Base Gasket (.020/0.5mm)	290-931-402	6025.5*
Base Gasket (.024/0.6mm)	290-931-403	6025.6
Base Gasket (.030/0.8mm)	290-931-404	6025.8
Carb Gasket 41mm (2 required)	293-250-042	6107*
Exhaust Gasket (2 required)	290-850-637	6080*
Headpipe Gasket	290-950-251	6150*
Starter O-Ring	278-000-694	6152
Flywheel Housing	290-850-605	6130
Rotary Valve Cover O-Ring	293-300-023	6250
Rotary Valve Shaft O-Ring	293-300-024	6260
Flywheel Cover O-Ring	290-831-555	6278

### 785 XP/GSX/GTX/SPX

	OEM No.	Part No.
Top Kit		6620
Complete Kit		6640
Head Cover O-Ring	290-831-550	6612*
Spark Plug O-Ring (2 required)	290-430-782	6220*
Cylinder O-Ring (2 required)	290-931-410	6185*
Water Jacket O-Ring (2 required)	290-931-420	6614*
Base Gasket (.012/0.3mm)	290-931-720	6035.3
Base Gasket (.017/0.4mm)	290-931-721	6035.4
Base Gasket (.020/0.5mm)	270-931-722	6035.5*
Base Gasket (.024/0.6mm)	290-931-723	6035.6
Base Gasket (.030/0.8mm)	290-931-724	6035.8
Carb Gasket 41mm (2 required)	293-250-042	6107*
Power Valve Gasket (2 required)	290-931-540	6618
Power Valve O-Ring (2 required)	290-430-110	6622
Exhaust Gasket	290-931-480	6082*
Head Pipe Gasket	290-931-500	6155*
Balance Shaft O-Ring	290-230-300	6624
Manifold O-Ring	290-831-765	6628
Rotary Valve Shaft O-Ring	293-300-024	6260
Starter O-Ring	278-000-694	6152
Flywheel Housing Gasket	290-931-470	6045
Flywheel Cover O-Ring	290-950-360	6632
Oil Pump O-Ring	293-300-018	6255
P.T.O. O-Ring	290430-782	6220

### SEA DOO 800 DI

	OEM No.	Part No.
800 DI Top Kit	*	6850
800 DI Complete Kit	ALL	6855
Head Cover O-Ring	420-831-550	6612*
Spark Plug O-Ring (2 Req'd)	420-430-782	6220*
Cylinder O-Ring (2 Req'd)	420-931-410	6185*
Water Jacket O-Ring (2 Req'd)	420-931-420	6614*
Base (3 Hole 0.12)	420-931-728	6035.3
Base (4 Hole 0.16)	420-931-728	6035.4*
Base (6 Hole 0.24)	420-931-728	6035.6
Power Valve O-Ring (2 Req'd)	290-931-765	6622
Power Valve Housing O-Ring	290-931-670	6750
Exhaust	290-931-481	6082*
Headpipe	420-931-503	6155*
Balance Shaft O-Ring	290-230-300	6624
Manifold O-Ring	290-831-767	6628
Rotary Valve Shaft O-Ring	293-300-024	6260
Starter O-Ring	278-000-694	6152
Flywheel Housing Gasket	290-931-470	6045
Flywheel Cover O-Ring	290-950-360	6632
Oil Pump O-Ring	293-300-018	6255
Case Plug O-Ring	290-250-890	6650
Intake Manifold O-Ring	420-850-520	6655
Rectifier Cover O-Ring	420-850-390	6784
Bearing Cover O-Ring	420-230-300	6624
Sump Cover O-Ring	420-950-360	6205

### SEA DOO 950 DI

	OEM No.	Part No.
950 DI Top Kit	2000+	6875
950 DI Complete Kit	2000+	6880
Head	420-931-706	6705*
Base (3 Hole 0.12)	420-931-905.3	6734.3*
Base (4 Hole 0.16)	420-931-905.4	6734.4*
Base (6 Hole 0.24)	420-931-9053.6	6734.6*
Reed (Not Req'd w/Stock Reeds)		6745
Power Valve O-Ring (2 Req'd)	290-850-460	6622*
Power Valve Housing O-Ring	290-931-670	6750*
Exhaust (2 Req'd)	293-250-081	6760*
Headpipe	420-931-990	6775*
Balance Shaft O-Ring	290-230-300	6624
Starter O-Ring	278-001-159	6790
Flywheel Cover	290-931-690	6795
Oil Pump O-Ring	293-300-018	6255
Engine Bottom Cover O-Ring	420-931-880	6782
Rectifier Cover O-Ring	420-850-390	6784
Compressor	420-230-300	6624
Compressor Gasket	420-931-870	6850
O-Ring	293-300-054	6862
O-Ring	293-300-076	6865
O-Ring	293-300-070	6868



## INDIVIDUAL GASKETS FOR YAMAHA

### WAVE JAMMER, WAVE RUNNER 500

	OEM No.	Part No.
Complete Kit		51-4803
Head	6K8-1181	2000
Carb	6K8-13556	2010
Thermostat Cover	655-12414	2020
Reed	6K8-13621	2030
Oil Seal Housing	6K8-15369	2040
Flywheel Cover	6K8-81365	2050
Flame Arrestor	6K8-13674	2060
Exhaust Cover #1	6K8-41124	2070
Exhaust Cover #2	6K8-41122	2080
Exhaust Cover Inner	6K8-41112	2090
Exhaust Cover Outer	6K8-41114	2100
Muffler Damper #1	6K8-14739	2110
Muffler Damper #2	6K8-14749	2120
Silencer	6K8-14755	2130
Upper Case	6K8-45113	2140

### 650 SUPERJET 90-93, WR111 90-93

	OEM No.	Part No.
Top Kit		2600
Complete Kit		2650
Head 77mm .050	6R7-11181	2205*
Base	6M6-11351	2220*
Carb (2 required)	6M6-13556	2230*
Top Manifold	6M6-13563	2240*
Lower Manifold	6M6-13566	2260*
Reed (2 required)	6M6-13621	2280*
Exhaust	6M6-14613	2310*
Oil Pump	6R8-13116	2340
Air Cleaner (2 required)	6M6-13674	2350
Flywheel Cover	6M6-81365	2360
Head Pipe	6R7-14755	2370
Outer Cover	6R7-41114	2380
Damper	6R7-14749	2390
Exhaust Pipe (2 required)	6M6-14739	2400
Head Cover	6M6-11193	2410

### 701 SUPERJET 94-95, BLASTER 93-95 WAVE RAIDER 96, WR111 94-95

	OEM No.	Part No.
Top Kit		2700
Complete Kit		2750
Head 82mm .050	61X-11181A	2215*
Base	6M6-11351	2220*
Carb (2 required)	6M6-13556	2230*
Top Manifold	61X-13563	2250*
Lower Manifold	61X-13566	2270*
Reed (2 required)	61X-13621	2290*
Exhaust Green	61X-14613	2330*
Oil Pump	6R8-13116	2340
Flame Arrestor (2 required)	6M6-13674	2350
Flywheel Cover	6M6-81365	2360
Silencer (aka Head Pipe)	6R7-14755	2370
Outer Cover	6R7-41114	2380
Damper	6R7-14749	2390
Exhaust Pipe	6M6-14739	2400
Head Cover	6M6-11193	2410

\* Denotes when the gasket is included in the Top End Gasket Set.

### 701 SUPERJET 96-99, WAVE BLASTER 96

	OEM No.	Part No.
Top Kit		2550
Complete Kit		2555
Head 82mm	62T-11181	2215*
Base	6M6-11351	2220*
Reed (2 required)	62T-13566	2830*
Carb Manifold	62T-13556	2820*
Carb Base (2 required)	-	5460
Exhaust Green	61X-14613	2330*
Oil Pump	6R8-13116	2340
Arrestor (2 required)	62T-13674	2825
Flywheel Cover	6M6-81365	2360
Head Pipe	6R7-17455	2370
Outer Cover	6R7-41114	2380
Damper	6R7-14749	2390
Exhaust Pipe	6M6-14739	2400

### 701 WAVE RAIDER 94-95, WAVE VENTURE 95+

	OEM No.	Part No.
Top Kit		2950
Complete Kit		2980
Head Green	62T-11181	2810*
Base	6M6-11351	2220*
Carb Base	62T-14398	5030*
Carb Manifold	62T-13556	2820*
Air Cover	62T-13674	2825
Flywheel Cover	6M6-81365	2360
Reed (2 required)	62T-13566	2830*
Exhaust Green	62T-14613	2850*
Muffler Damper 1	62T-14739	2860
Head Pipe	62T-14749	2870
Exhaust Outer Cover #1	62T-41114	2880
Exhaust Inner Cover	62T-41122	2890
Exhaust Outer Cover #2	62T-41124	2900
Oil Pump	6R8-13116	2340
Ignition Box Cover	6M6-81921	2116A

### 760 WAVE RAIDER 96+, BLASTER II 96+, XL760W

	OEM No.	Part No.
Top Kit		2990
Complete Kit		2992
Head .025 Stainless	64X-11181	3200*
Head .050 86mm	Ultimate	3210
Base	6M6-11351-A2	3205*
Carb Base (2 required)	62T-14398	5460*
Carb Manifold	64X-13556	3220*
Arrestor (2 required)	64X-13674	3230*
Reed (2 required)	62T-13566	2830*
Exhaust Green	62T-14613	2850*
Flywheel Cover	6M6-81365	2360
Head Pipe	64X-14749	2870
Exhaust Outer Cover #1	62T-41114	2880
Exhaust Inner Cover	62T-41122	3240
Outer Cover Exhaust	62T-41124	3250
Oil Pump	6R8-13116	2340

### GP800 98+

	OEM No.	Part No.
Top Kit		3520
Complete Kit		3530
Head .025 Stainless		3400*
Head .050 82mm	Ultimate	3410
Base (2 required)		3420*
Carb Base		5460
Carb Manifold		3430*
Exhaust Green		3450*
Head Pipe		3460
Power Valve (2 required)		3470
Exhaust Section		3480
Oil Pump		2340

FUEL SYSTEMS  
ENGINE/GASKETS  
EXHAUST  
DRIVE LINE HANDLING  
ELECTRICAL  
WATERLINE /BILGE  
STEERING & CONTROLS  
BODY  
ACCESSORIES  
/HARDWARE  
SERVICE TOOLS  
CHEMICAL  
FREESTYLE & BOOSXR  
FOUR STROKE

# INDIVIDUAL GASKETS FOR YAMAHA

## YAMAHA 1300 GPR

### 1100 WAVE VENTURE / WAVE RAIDER

	OEM No.	Part No.
Top Kit		4520
Complete Kit		4530
Head .050 82mm	63M-11181	4400*
Base	63M-11351	4415*
Carb Base	63M-14398	5030
Carb Manifold	63M-13556	4420*
Reed (2 required)	63M-13566	4430*
Exhaust	63M-14613	4450*
Muffler Damper 1	63M-14739	4455
Muffler Damper 2	63M-14749	4460
Exhaust Outer Cover (2 required)	63M-41114	4470
Exhaust Inner Cover	63M-41122	4480
Head Cover	63M-11193	4500
Flywheel Cover	63M-81365	4505
Oil Pump	63M-13116	4510

	OEM No.	Part No.
1300 Top Kit		3800
1300 Complete Kit		3810
Head .025 Stainless Steel	66V-11181	3605*
Base (3 Req'd)	66E-11351	3420*
Manifold		3620*
Reed	NOE	3435
Reed Center	NOE	3440
Power Valve (3 Req'd)	66E-1131B-01	3470
Exhaust	66V-14613	3650
Head Pipe	66V-14739	3660
Chamber	66V-14749	3670
Outer Cover #1	66V-41114	3680
Outer Cover #2	66V-41124	3690
Tail Cone	66V-14623	3700
Starter O-Ring	1FK-81847	3490
Oil Pump	63M-13116	2340

### YAMAHA GP 1200, XL 1200 98+

	OEM No.	Part No.
Top Kit		4680
Complete Kit		4685
Head .025 86mm	65U-11181	4600*
Head .050 86mm Green	Ultimate	4610
Base	65U-11351	4615*
Carb Base XL 1200 W	65U-13556	5460
Carb Manifold	64X-14162	4620*
Spark Arrester	-	4630
Reed (2 required)	65U-13566	4430*
Exhaust	65U-14613	4650*
Muffler Damper 1	63M-14739	4455
Head Pipe	63M-14749	4460
Exhaust Outer Cover (2 required)	63M-41114	4470
Exhaust Inner Cover	63M-41122	4480
Head Cover	63M-11193	4500
Flywheel Cover	63M-81365	4505
Oil Pump	63M-13116	4510



## INDIVIDUAL GASKETS FOR KAWASAKI

### 440 ALL

	OEM No.	Part No.
Complete Kit 77-80		51-1203
Complete Kit 81-92		51-1503
Head	11004-3707	5200
Base	11009-505	5240
Intake	11009-3785	5250
Carb Base 38mm	11009-3786	5030
Housing Pre 82	92065-515	5270
Exhaust	11009-3779	5280
Headpipe Green	11060-3710	5290
Arrester 38mm	11060-3702	5080

### YAMAHA GP 1200R, XL 1200LTD

	OEM No.	Part No.
Top Kit		3730
Complete Kit		3740
Head .025 Stainless Steel	66V-11181	3600*
Base (3 Required)	66E-11351	3420*
Carb Base (3 Required)	66E-14398	3425*
Carb Manifold	66V-13558	3620*
Reed	-	3435
Reed Center	-	3440
Power Valve (3 Required)	66E-1131B-0	3470
Exhaust Green	66V-14613	3650
Head Pipe	66V-14739	3660
Chamber	66V-14749	3670
Outer Cover #1	66V-41114	3680
Outer Cover #2	66V-41124	3690
Tail Cone	66V-14623	3700
Starter O-Ring	1FK-81847	3490
Oil Pump	63M-13116	2340
Head Cover	66V-11193	3610

### 550 1982-85, 1986-90

	OEM No.	Part No.
Top Kit 1982-85		5550
Complete Kit 1982-85		5560
Top Kit 1986-90		5570
Complete Kit 1986-90		5580
Head All	11004-3709	5400*
Base	11009-3782	5430*
Intake (2 required)	11009-3785	5250*
Carb Base 38mm Pre 86	11009-3786	5030*
Carb Base 44mm 86-90	11060-3743	5460*
Exhaust	11009-3779	5280*
Headpipe Pre-86	11009-3051	5480
Conn Pipe Lower Pre 86	11060-3730	5490
Headpipe	11060-3726	5500
Conn Pipe 86-90	11060-3727	5510
Chamber 86-90	11060-3278	5520
Arrester 38mm Pre 86	11060-3702	5080
Arrester 44mm 86-90	11060-3744	5540

\* Denotes when the gasket is included in the Top End Gasket Set.





## INDIVIDUAL GASKETS FOR KAWASAKI

### 550sx 1991-95

	OEM No.	Part No.
Complete Kit		51-2403
Head .010 Stainless	11004-3706	51-2409
Head .040 Fiber		51-2406
Base .010 Stainless	11009-3780	5630
Base .020 Fiber		5635
Reed	11009-3787	5640
Intake	11009-3788	5650
Keihin 38mm	11060-3716	5660
Exhaust	11009-3779	5280
Headpipe	11060-3726	5500
Conn Pipe	11060-3727	5510
Chamber	11009-2446	5520

### KAWASAKI 650, X2/TS/SC

	OEM No.	Part No.
650 Complete		5940
650 X2, TS Complete		5960
Head .010 Stainless	11004-3710	5800
Head .040 Green	Ultimate	5830
Base	11009-3775	5850
Reed	11009-3731	5860
Keihin 28mm Carb Base	11009-3747	5870
Keihin 38mm Carb Base	11060-3716	5660
Exhaust	11009-3722	5880
Head Pipe	11009-3752	5890
Head Pipe 46mm ID Green	11009-3752	5900
Muffler TS	11060-3718	7120
X-2 Conn Pipe	11009-3724	5910
Control Valve All	11060-3723	7150

### 750SX, SXI, SXI PRO

	OEM No.	Part No.
Top Kit	All 750	7200
Complete Kit	SX/SXI	7210
Head .010 Stainless	11004-3714	7000*
Head .020 Head Copper	Copper	7010
Base	11060-3711	7040*
Reed A SX(4pcs) SXI(2pcs)	11060-3717	7050*
Reed B SXI(2pcs)	11060-3757	7430*
40mm Carb	11060-3716	7060*
40mm Carb SXI 96+	11060-3761	7065*
Exhaust (2 required)	11060-3759	7070*
Head Pipe SX, SXI	11060-3712	7080
Upper Muffler SX, SXI	11060-3713	7090
Muffler SX, SXI	11060-3714	7140
Control Valve All	11060-3723	7150

\* Denotes when the gasket is included in the Top End Gasket Set.

### 750 SS, XI, XIR

	OEM No.	Part No.
Top Kit	All 750	7200
Complete Kit	SS/XI	7220
Complete Kit	SS 92-93	7240
Complete Kit	XIR	7230
Head .010 Stainless	11004-3714	7000*
Base All	11060-2711	7040*
Reed (4pcs) SS92+, XI93-95, XI	11060-3717	7050*
Reed A XI 96 (2 pcs)	11060-3717	7050*
Reed B XI 96 (2 pcs)	11060-3757	7430*
40mm Carb SS, XI, XIR	11060-3716	7060*
40mm Carb XI 96	11060-3758	7060*
Exhaust All	11060-3721	7070
Head Pipe SS 92-93	11060-3720	7100
Head Pipe SS 94+, ST, XI 93+	11060-3732	7110
Head Pipe (XIR)	11009-3752	5900
Muffler XI, SS	11060-3718	7120
Control Valve All	11060-3723	7150

### 750 STS, ZXI

	OEM No.	Part No.
Top Kit	ALL 750	7200
750 Complete	95 STS	7225
750 Complete	ZXI 95+	7245
Head .010 Stainless	11004-3714	7000*
Base All	11060-3711	7040*
Reed A ZXI, STS (2), ST (4)	11060-3717	7050*
Reed B ZXI, STS (2)	11060-3757	7430*
40mm Carb ZXI, STS (2)	11060-3758	7060*
Exhaust STS 95-96, ZXI (2)	11060-3721	7070*
Headpipe 95 STS	11060-3732	7110
Headpipe 96 STS	11060-3771	7115
Headpipe ZXI 95-96	11060-3754	7470
Muffler 1 95 STS	11060-3718	7120
Exhaust Joint STS 96	11060-3763	7125
Muffler 1 96 STS	11060-3766	7135
Muffler 2 96 STS	11060-3770	7145
Muffler ZXI 95-96	11060-3755	7480
Control Valve All	11060-3723	7150

### KAWASAKI 800 SXR

	OEM No.	Part No.
800 Top Kit		7300
800 Complete Kit		7310
Head Stainless Steel .010	11004-3720	7005*
Base SXR	11060-3711	7040*
Reed SXR (4 required)	11060-3717	7050*
Reed SXR (2 required)	11060-3757	7430*
40mm Carb SXR (2 required)	11060-3761	7067*
Exhaust SXR (2 required)	11060-3759	7075*
Headpipe SXR	11060-3712	7080
Upper Muffler SXR	11060-3713	7090
Muffler SXR	11060-3714	7140

### KAWASAKI 900 ZXI 95+

	OEM No.	Part No.
Top Kit		7500
Complete Kit		7520
Head .010 Stainless	11004-3713	7400*
Head .040 Fiber		7410
Base	11060-3752	7420*
Reed Engine (3 required)	11060-3717	7050*
Reed Carb (3 required)	11060-3757	7430*
Exhaust (3 required)	11060-3756	7450*
Carb Base	11060-3753	7460
Headpipe	11060-3754	7470
Muffler	11060-3755	7480

FUEL SYSTEMS  
ENGINE/GASKETS  
EXHAUST  
DRIVE LINE HANDLING  
ELECTRICAL  
WATERLINE /BILGE  
STEERING & CONTROLS  
BODY  
ACCESSORIES /HARDWARE  
CHEMICAL  
FREESTYLE & 800SXR  
FOUR STROKE

## KAWASAKI 1100ZXI 96-98

	OEM No.	Part No.
Top Kit		7670
Complete Kit		7680
Head .010 Stainless	11004-3715	7600
Head .040 Fiber		7605
Base	11060-3760	7615
Reed Engine	11060-3717	7050
Reed Carb	11060-3757	7630
Exhaust	11060-3767	7650
Carb	11060-3775	7652
Carb	11060-3776	7655
Headpipe	11060-3768	7660
Muffler	11060-3769	7665

## KAWASAKI ULTRA 150 99+

	OEM No.	Part No.
Top Kit		7830
Complete Kit		7835
Head Stainless Steel .010*	11004-3717	7700*
Base	11060-3783	7715*
Water Pipe	11060-3785	7720
Reed (3 Req'd)	11060-3717	7050*
Reed Carb (3 Req'd)	11060-3757	7630*
Exhaust (3 Req'd)	11060-3785	7750*
Carb (3 Req'd)	11060-3788	7760
Head Pipe	11060-3786	7770
Exhaust Body	11060-3787	7780
Flywheel Cover	11060-3803	7790

## INDIVIDUAL GASKETS FOR POLARIS

### 700 HURRICANE, VIRAGE, FREEDOM

	OEM No.	Part No.
Top Kit		4375
Complete Kit		4378
Head O-Ring (2 required)	5410931	4300*
Cylinder O-Ring (2 required)	5410932	4305*
Spark Plug O-Ring (2 required)	5410917	4310*
Base (2 required)	5811057	4315*
Base Virage-Freedom (2 required)	5811784	4805*
Reed Engine Side	N.O.E	4317
Reed Carb Side	N.O.E	4319
Carb (2 required)	5830043	4320*
Arrestor	5830062	4325
Exhaust (2 required)	5811045	4330*
Headpipe (2 required)	5830051	4335*
Flywheel Cover	5811145	4337
Water Manifold (2 required)	5830061	4339
Oil Pump O-Ring	5411056	4340
Thermostat Housing	5410860	4353
Crank O-Ring	5410613	4356
Starter O-Ring (2 required)	3240114	4359

### POLARIS 650/750

	OEM No.	Part No.
650 Top Kit		4200
650 Complete Kit		4210
750 Top Kit		4220
750 Complete Kit		4230
Head 650 .010 Stainless (3 req'd)	3240057	4000*
Head 750 .040 Stainless (3 req'd)	3240213	4010*
Head 650 .040 Fiber	Ultimate	4020
Base .020 (3 required)	3240055	4040*
Reed (6 required)	3084148	4050*
Carb (6 required)	3240128	5030*
Arrestor	5830013	4065
Exhaust (3 required)	5211489	4070*
Headpipe	5830038	4080*
Water Manifold (3 required)	3082937	4100
Thermostat Housing	5410781	4110
Oil Pump O-Ring	3083127	4112
Starter O-Ring (2 required)	3240114	4359

## POLARIS 780, 785 PRO

	OEM No.	Part No.
Head 780 Stainless (3 required)	3240251	4035*
Head 785 Stainless (3 required)	3240305	4037*
Base (3 required)	3240249	4040*
Reed (3 required)	3084148	4050*
Carb (3 required)	3240128	5030*
Carb 785 (3 required)	3240358	9240*
Arrestor (3 required)	5830013	4065*
Arrestor 785 (3 required)	5830115	5540*
Exhaust	5211623	4077*
Exhaust 785	5211725	4078
Exhaust 785 O-Ring (6 required)	5411311	4079
Head Pipe	5830038	4080*
Power Valve 785 (3 required)	3240313	4085
Water Manifold	3082937	4100
Oil Pump O-Ring	3083127	4112
Thermostat Housing	5410781	4110
Starter O-Ring	3240114	4359

## POLARIS 900/1050

	OEM No.	Part No.
Top Kit 900		4380
Complete Kit 900		4383
Top Kit 1050		4385
Complete Kit 1050		4390
Head O-Ring (3 required)	5410931	4300*
900 Cylinder O-Ring (3 required)	5411044	4303*
1050 Cylinder O-Ring (3 required)	5410932	4305*
Spark Plug O-Ring (3 required)	5410917	4310*
Base 900 (3 required)	5811057	4315*
Base 1050 (3 required)	5830123	4316
Reed		4318
Carb (3 required)	5830043	4320
Arrestor	5830062	4325
Exhaust (3 required)	5811045	4330*
Headpipe	5830051	4335
Flywheel Cover	5811145	4337
Water Manifold	5830061	4339
Oil Pump O-Ring	5411056	4340
Thermostat Housing	5410860	4353
Crank O-Ring	5410613	4356
Starter O-Ring	3240114	4359

## INDIVIDUAL GASKETS FOR TIGER SHARK

### TIGER SHARK 639, 644

	OEM No.	Part No.
Top Kit 639/644		3100
639 Complete Kit		3110
644 Complete Kit		3120
Head	3008-174	3000*
Head 639,644 77MM .040	Ultimate	3010
Base	3008-050	3030*
Reed (4 required)	3008-076	3040*
Carb Base 44mm	3008-057	5460*
Exhaust (2 required)	3008-080	3060*
Head Pipe	3008-081	3070
Connector Pipe 644 only	3008-082	3080
Air Cleaner	3008-058	3090

\* Denotes when the gasket is included in the Top End Gasket Set.

# INDIVIDUAL GASKETS BY SECTION

## HEAD GASKETS



Head gaskets for all applications including high performance racing applications. All gaskets meet or exceed the OEM manufacturers specifications.

Head gaskets are available in Metal, Copper, and "Ultimate" Green fiber.

Sea Doo Cylinder	Type	Part No.
O ring set 580 92+	O-Ring	6170
O ring set 650	O-Ring	6180
O ring set 720/785	O-Ring	6185

Sea Doo Head Cover	Type	Part No.
O ring 580 Yellow Engine	O-Ring	6200
O-Ring 580 White Engine/720	O-Ring	6205
O ring 650	O-Ring	6210
O ring 785	O-Ring	6612

Polaris	Thickness	Type		Part No.
650	0.040	Green	(3 Required)	4020
750	0.040	Green	(3 Required)	4030
650	0.010	Metal	(3 Required)	4000
750	0.010	Metal	(3 Required)	4010
780	0.010	Metal	(3 Required)	4035
785	0.010	Metal	(3 Required)	4037

Polaris Head O-Ring	Part No.
700 Hurricane/900/1050	4300

Polaris Cylinder O-Ring	Part No.
700 Hurricane/1050	4305
900	4303

Yamaha	Thickness	Type	Part No.
500 All	0.040	Fiber	2000
500 All	0.050	Green	2005
650 All 77mm	0.050	Green	2205
701 All 82mm	0.050	Green	2215
701 W/Raider	0.050	Green	2810
760 86mm	0.050	Green	3210
GP800	0.050	Green	3410
1100 82mm	0.050	Green	4400
1200 86mm	0.050	Green	4610
760 86mm	0.025	Metal	3200
GP800	0.050	Metal	3400
1200 86mm	0.025	Metal	4600
GP1200R,XL1200LTD	0.025	Metal	3600

Kawasaki	Thickness	Type	Part No.
440 77-80	0.040	Fiber	51-1206
440 81-92	0.040	Fiber	5200
550 82-90	0.040	Fiber	5400
550 91-95	0.040	Fiber	51-2406
650 All	0.040	Green	5830
750 All	0.040	Green	7020
900 ZXI	0.040	Green	7410
1100 ZXI	0.040	Green	7605
550 91-	0.010	Metal	51-2409
650 All	0.010	Metal	5800
750 All	0.010	Metal	7000
900 ZXI	0.010	Metal	7400
1100 ZXI	0.010	Metal	7600
550 91-	0.020	Copper	51-2410
750 All	0.020	Copper	7010
800 SX-R	0.010	Metal	7005

# ThreeBond



1211 (White)



1207 D (Silver)

## THREE BOND SILICON GASKET

### #1211 (White) Silicon Liquid Gasket

High grade silicon liquid gasket used by many OEM's in aluminum case assembly. 1211 is tack free in 90 minutes and fully cured in 24 hours.

### #1207D (Silver) Quick Dry Silicon Gasket

Crankcase sealer for large gaps, sheet metal, tough to seal areas, and vertical applications. 1207D is tack free in 5 minutes and fully cured in 24 hours.

Descriptions	Part No.
Silicon Liquid Gasket (White)	1211AT100
Quick Dry Silicon Liquid Gasket (Silver)	1207B100G

FUEL SYSTEMS  
ENGINE/GASKETS  
EXHAUST  
DRIVE LINE HANDLING  
ELECTRICAL  
WATERLINE /BILGE  
STEERING & CONTROLS  
BODY  
ACCESSORIES  
SERVICE TOOLS /HARDWARE  
CHEMICAL  
FREESTYLE & BOOSXR  
FOUR STROKE

# INDIVIDUAL GASKETS BY SECTION

## INTAKE & REED GASKETS (Intake Manifold to Cylinder or Cases)

Polaris	OEM#	Part No.
650/750/780/785 Reed	308448	4050
900/1050/Reed		4318
700/Hurricane Reed Engine Side		4317
700/Hurricane Reed Carb Side		4319

Yamaha	OEM#	Part No.
500 Reed	6K8-13261	2030
650 All Reed	6M6-13621	2280
650 Top Intake	6M6-13563	2240
650 Bottom Intake	6M6-13566	2260

Kawasaki	OEM#	Part No.
440/550 Intake	11009-3785	5250
550SX Intake	11009-3788	5650
550SX Reed	11009-3787	5640
650 All Reed	11060-3703	5860
750/900/1100 Engine	11060-3717	7050
750/900/1100 Reed Carb	11060-3757	7430

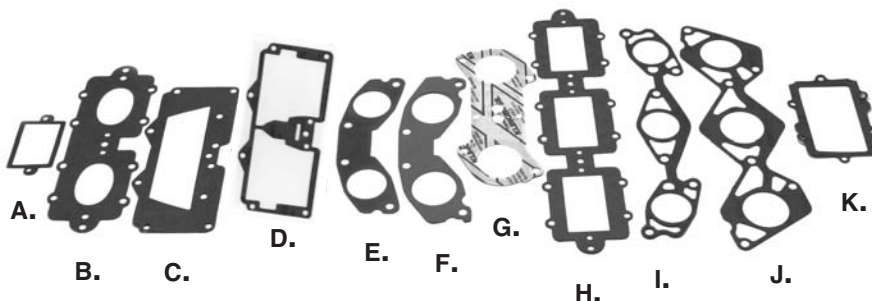

Yamaha	OEM#	Part No.
A. 701 Reed	61X-13621	2290
B. 760 W/Rdr Reed/701 96+	62T-13566	2830
C. 701 Top Manifold	61X-13563	2250
D. 701 Lower Manifold	61X-13566	2270
E. SJ,W/Blster 701 96+/WRdr 701	62T-13556	2820
F. 760 Carb Manifold	64X-13556	3220
G. 800 Carb Manifold	64E-13556	3430
H. 1100/1200 Reed	63M-13566	4430
I. 1100 Carb Manifold	64M-13556	4420
J. 1200 Carb Manifold	64X-14162	4620
K. GP1200R/XLL1200 Reed		3435



## EXHAUST HEAD PIPE GASKETS (Manifold to Pipe)

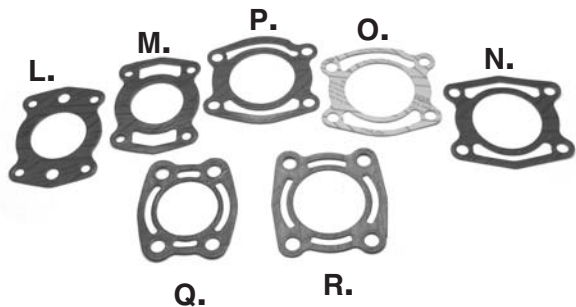

Sea Doo	OEM#	Part No.
L. 580 -92	290-950-250	6140
M. 580 92+/650/720	290-950-251	6150
N. 785	290-931-500	6155
O. 951 97	290-931-487	6770
P. 951 98+	290-250-080	6775

Polaris	OEM#	Part No.
Q. 650/750/780/785	5830038	4080
R. 700/Hurricane/900/1050	5830051	4335

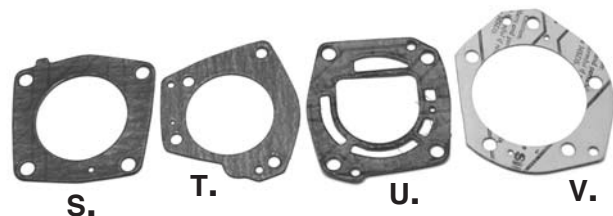

Yamaha	OEM#	Part No.
S. 650/701	6R7-14755	2370
T. 701 WRD 94-95	62T-14749	2870
T. 760	64X-14749	2870
U. 1100/1200	63M-14749	4460
V. 800	66E-14749	3460

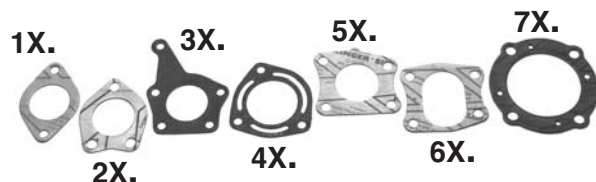

Kawasaki	OEM#	Part No.
1X. 440/550	11009-3051	5290
2X. 650 All (46mm ID)	11009-3752	5900
3X. 750 SX/SX1	11060-3712	7080
4X. 750 SX/SX1 Front	11060-3713	7090
5X. 750 SS 92-95	11060-3720	7100
6X. 750 X1 93-96	11060-3732	7110
7X. 900	11060-3755	7480
1100	11060-3769	7665

# INDIVIDUAL GASKETS BY SECTION (Cylinder to Manifold)

## EXHAUST MANIFOLD GASKETS

(cylinder to manifold)

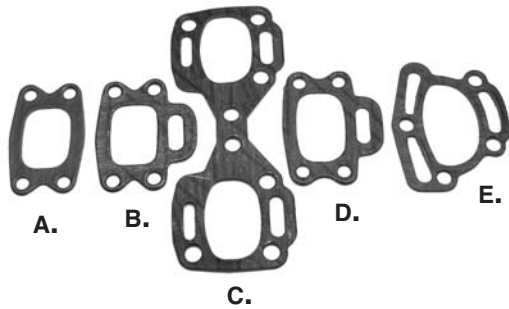

A.

B.

D.

E.

C.

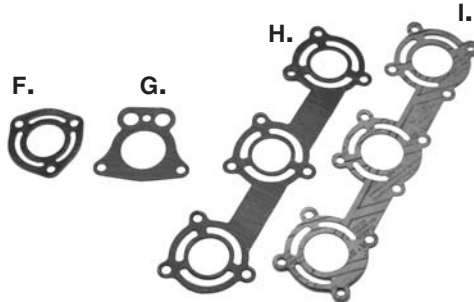

F.

G.

H.

I.

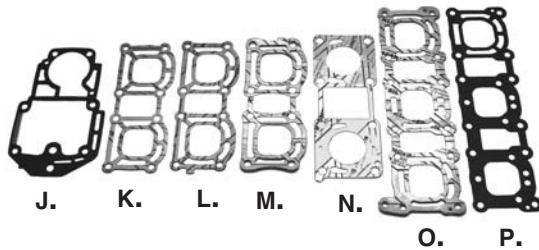

J.

K.

L.

M.

N.

O.

P.

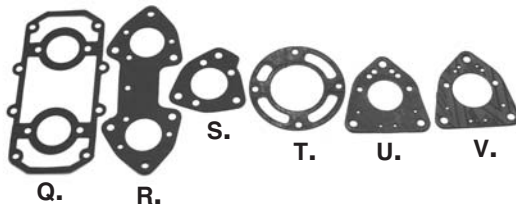

Q.

R.

S.

T.

U.

V.

Sea Doo	OEM#	Part No.
A. 580 All -91	420-850-632	6050
B. 580 All 92+	290-850-635	6060
C. 785	290-931-480	6082
D. 650/720	290-850-637	6080
E. 951	290-250-081	6760

Polaris	OEM#	Part No.
F. 650/750	5211489	4070
G. 700/Hurricane/900/1050	5811045	4330
H. 780	5211623	4077
I. 785	5211725	4078

Yamaha	OEM#	Part No.
J. 500	6K8-45113	2140
K. 650 All	6M6-14613	2310
L. 701	61X-14613	2330
M. 701/760 W/Rdr	62T-14613	2850
N. 800	66E-14613	3450
O. 1100	63M-14613	4450
P. 1200	65W-14613	4650

Kawasaki	OEM#	Part No.
Q. 440/550	11009-3779	5280
R. 650 (86-90)	11060-3739	5880
S. 650/750 (2 required)	11060-3759	7070
T. 750 SS-X1	11060-3718	7120
U. 900	11060-3756	7450
V. 1100	11060-3767	7650



2006 WORLD FINALS  
LAKE HAVASU, AZ  
PHOTO COURTESY OF  
JIN OMURA

FUEL SYSTEMS	ENGINE/GASKETS	EXHAUST	DRIVE LINE HANDLING	ELECTRICAL	WATERLINE /BILGE	STEERING & CONTROLS	BODY	ACCESSORIES	SERVICE TOOLS /HARDWARE	CHEMICAL	FREESTYLE & BOOSXR	FOUR STROKE
--------------	----------------	---------	---------------------	------------	------------------	---------------------	------	-------------	-------------------------	----------	--------------------	-------------

# INDIVIDUAL GASKETS BY SECTION



## BASE GASKETS

Sea Doo	OEM#	Part No.
580 -91	290-850-775	6000
580 92+/650	290-931-161	6020.3
580 92+/650	290-931-162	6020.4
580 92+/650	290-931-163	6020.5
580 92+/650	290-931-164	6020.6
580 92+/650	290-931-165	6020.8
720 0.3mm	290-931-400	6025.3
720 0.4mm	290-931-401	6025.4
720 0.5mm	290-931-402	6025.5
720 0.6mm	290-931-403	6025.6
720 0.8mm	290-931-404	6025.8
785 0.3mm	290-931-720	6035.3
785 0.4mm	290-931-721	6035.4
785 0.5mm	290-931-722	6035.5
785 0.6mm	290-931-723	6035.6
785 0.8mm	290-931-724	6035.8
951 97	290-931-680	6730.3
951 97	290-931-681	6730.4
951 97	290-931-682	6730.6
951 98+	290-931-685.5	6732.5
951 98+	290-931-686.6	6732.6
951 98+	290-931-687.8	6732.8

Polaris	Part No.
650/750/780/785	4040
700/Hurricane/900/1050	4315

Yamaha	OEM#	Part No.
760	6M6-11351-A200	3205
650/701 All		2220
GP800	66E-11351-0000	3420
1100/1200	63M-11351-010	4415

Kawasaki	OEM#	Part No.
440 All		5240
550 80-90	11009-3782	5430
550 91-93	11009-3780	5635
550 91-93 Copper		51-2417
650 All	11009-3775	5850
750 All	11060-3711	7040
900	11060-3752	7420
1100	11060-3760	7615



## HEAD PIPE GASKET FOR AFTERMARKET

Pipe	Part No.
Riva WaveRaider (3 Hole)	9070
Riva All Others (3 Hole)	9060
R&D 3 Bolt	9080
R&D 4 Bolt	9090
Factory Pipe All (46mm ID)	5900
Factory Pipe 785 (Spec 1)	6155
Factory Pipe 785 (Spec 2)	6158
Factory Pipe Sea Doo 650/720	9010
Factory Pipe Kaw 550 LTD	9000
Coffman Pipe 550 Climax	9020
Coffman 750 SX Rocket Mod	9030
Coffman 750 SS, XI, ST Rocket	7100A
Coffman 750 XI (Hurricane)	7105



## R&D Dominator Base Gaskets

Yamaha	Thickness	Part No.
Superjet	.020 - 0.5mm	070-00020
Superjet	.040 - 1.0mm	070-00040
Superjet	.060 - 1.5mm	070-00060
Kaw 750/800	.060 - 1.5mm	071-00060



## HIGH PERFORMANCE BASE GASKETS

Kawasaki	Thickness	Part No.
800 SXR	.020 - 0.5mm*	B0075020C
800 SXR	.030 - 0.75mm**	7040C
800 SXR	.040 - 1.00mm**	7040D
800 SXR	.050 - 1.25mm**	7040E
800 SXR	.060 - 1.50mm**	7040F

\*Metal Gasket \*\*Fiber gasket with a metal core



## CARBURETOR BASE GASKETS

Description	Fiber	Green
Mikuni 38mm	5030	9230
Mikuni 40mm	6107	9235
Mikuni 44mm	5460	9240
Mikuni 46mm	9245	9250
Mikuni 48mm		9252
Mikuni 48mm (SD951 I Series)		6740
Mikuni 50mm		9257
Keihin 42mm	9210	9220
Keihin 38mm	5660	9200
Keihin 40mm	7060	9205



## COPPER BASE GASKET

## TBM 800 SXR BASE GASKETS

Boost your stock SX-R 800 compression between 10psi to 20psi over stock with these copper base gaskets without sacrificing reliability. Test results confirm an increase in acceleration and midrange power without losing peak RPM. 2006 Stock Class legal.

Kawasaki 800 SX-R	Part No.
Copper Base Gasket .005	TBM125-005
Copper Base Gasket .002	TBM125-002



## POLY BASE GASKET

## TBM 800 SXR BASE GASKETS

.010" poly base gasket gives you an alternative to the TBM .005" copper base gasket if you would like to run higher port timing. Some tuners will prefer this gasket over the copper depending on the variations in port heights in the stock cylinders. 2006 Stock Class legal.

Kawasaki 800 SX-R	Part No.
Poly Base Gasket .010	TBM125-010

